

N21103

# FIT KIT

# C

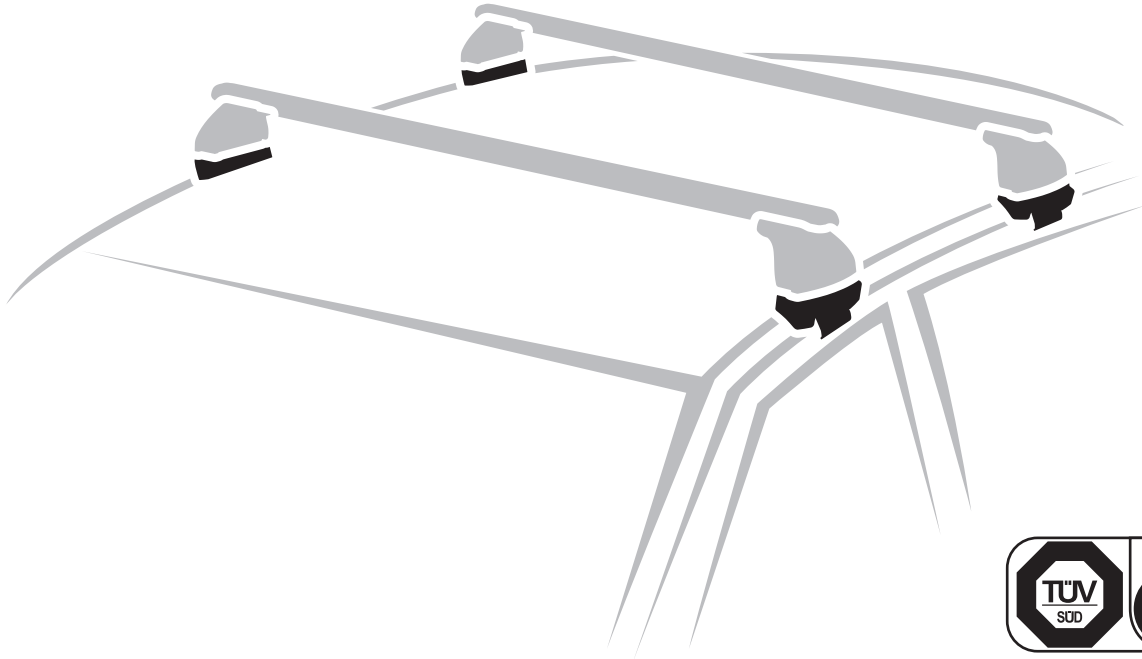



# C103

91CA0066 r08

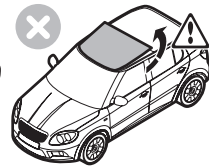
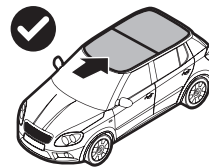
  
 ISTRUZIONI  
 AGGIORNATE  
 UPDATED  
 INSTRUCTIONS



**Non aprire**  
**Don't open**  
 Ne pas ouvrir  
 Öffnen Sie nicht  
 No abrir

COMPATIBILE PER - COMPATIBLE FOR - COMPATIBLE POUR COMPATIBLE PARA - KOMPATIBEL FÜR			
FIAT 500L		5	09/12 → 12/22
FIAT 500L Living		5	07/13 → 05/17
FIAT 500L Trekking		5	11/13 → 05/17
FIAT 500L Wagon		5	06/17 → 03/21
FIAT 500 Cross		5	06/17 → 12/22

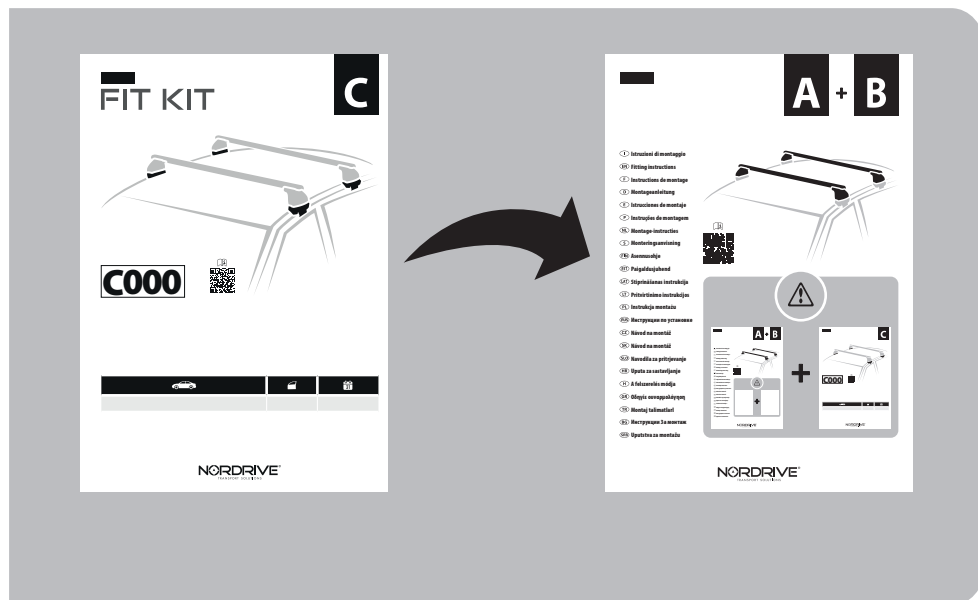

- I** Iniziare dal manuale **A+B** prima di proseguire con queste istruzioni **C**.
- EN** Before following these instructions **C**, please start firstly the manual **A+B**.
- F** Avant de suivre ces instructions **C**, veuillez commencer par le manuel **A+B**.
- D** Lesen Sie zuerst die Anleitung von **A+B**, bevor Sie die folgende Anweisung weiterlesen **C**.
- E** Inicie desde el manual de **A+B** antes de continuar con estas instrucciones **C**.
- P** Antes de seguir estas instruções **C**, leia o manual **A+B**.
- NL** Voordat u deze instructies **C** volgt, dient u eerst de handleiding **A+B** te starten.
- S** Innan ni följer dessa instruktioner **C**, vänligen läs manualen **A+B**.
- FIN** Aloita **A+B** -oppaasta, ennen kuin jatkat näiden ohjeiden noudattamista **C**.
- EST** Enne nende juhiste **C** järgimist alustage kõigepealt **A+B** kasutusjuhendit.
- LAT** Pirms izpildāt šos norādījumus **C**, lūdzu, vispirms sāciet **A+B** rokasgrāmatu.
- LT** Prieš pradėdant sekti šias instrukcijas **C**, prašome perskaityti vadovą **A+B**.

- PL** Przed wykonaniem tych instrukcji **C** należy najpierw zapoznać się z instrukcją **A+B**.
- RUS** Прежде чем приступить к выполнению этих инструкций **C**, начните с руководства **A+B**.
- CZ** Než budete pokračovat v těchto pokynech **C**, začněte od manuálu **A+B**.
- SK** Predtým ako budete postupovať podľa návodu, prosím prečítajte návod **A+B**.
- SLO** Pred vykonaním týchto pokynov **C** najskôr spustite príručku **A+B**.
- HR** Prije upotrebe ovih uputa **C**, prvo pokrenite priručnik **A+B**.
- H** Mielőtt követné ezt az utasítást **C**, olvassa el az **A+B** használati útmutatóját.
- GR** Διαβάστε τις οδηγίες του **A+B** προτού ακολουθήσετε αυτές τις οδηγίες **C**.
- TR** Bu talimatları uygulamadan önce **C**, lütfen öncelikle **A+B** kılavuzunu başlatın.
- BG** Преди да следвате тези инструкции **C**, прочетете ръководството на **A+B**.
- SRB** Pre nego što sledite ova uputstva **C**, molimo vas pročitajte priručnik **A+B**.



# C103 FIT KIT

Contenuto • Content • Contenu • Inhalt • Contenido

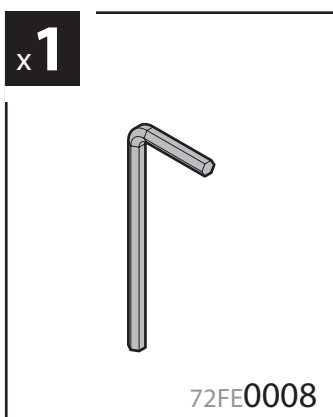
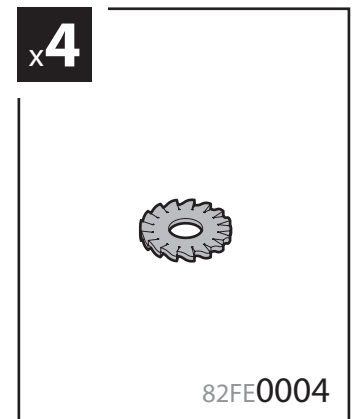
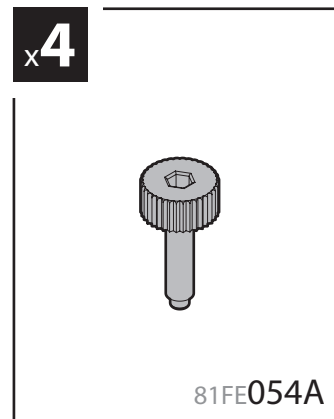
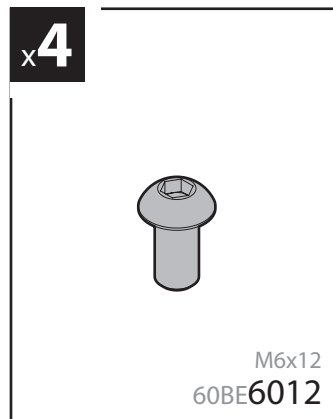
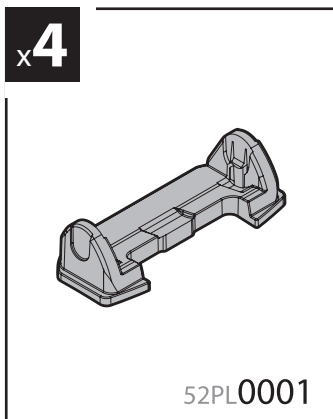
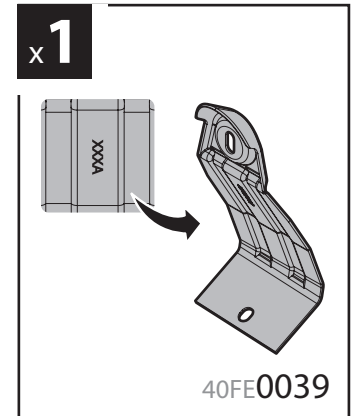
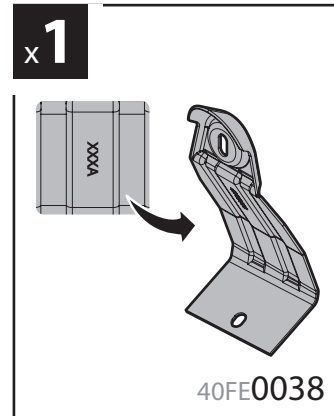
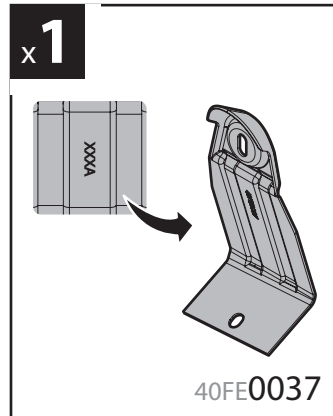
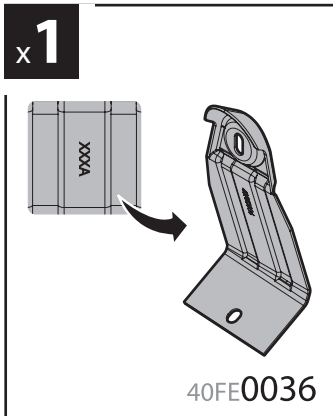
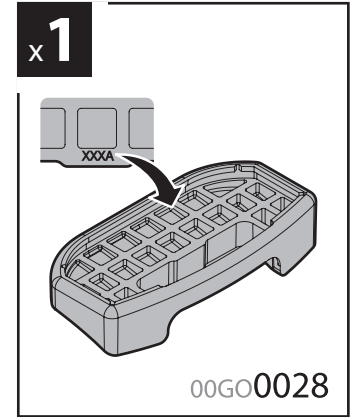
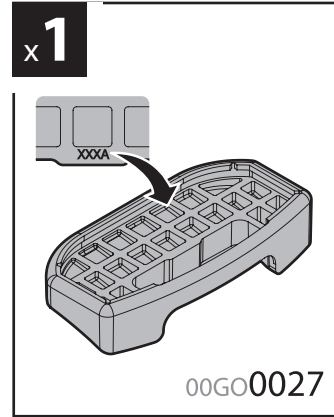
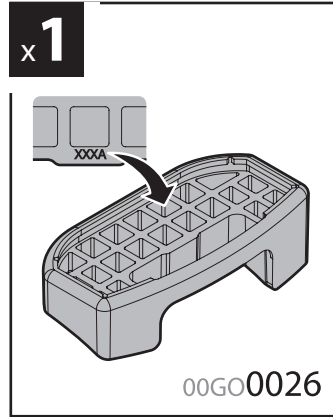
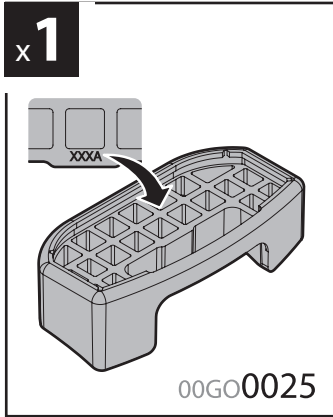

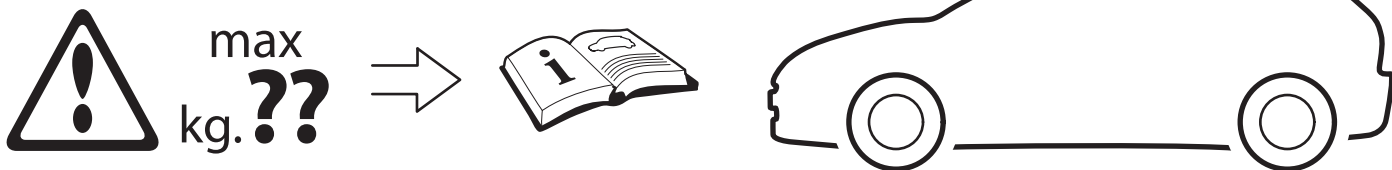
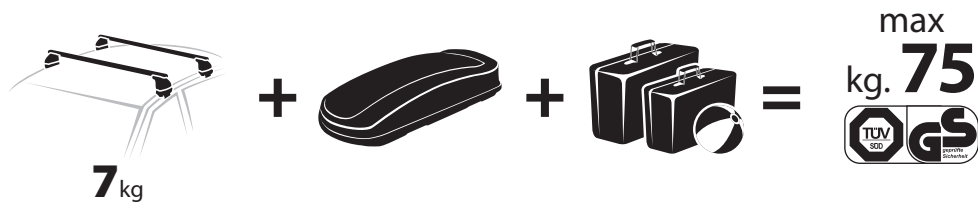

Montaggio • Fitting instructions • Montage • Montageanleitung • Montaje

3.1

SETTINGS

			EVOS STANDARD		EVOS LP LOW PROFILE	
			Front	Rear	Front	Rear
 FIAT 500L FIAT 500 Living FIAT 500 Trekking FIAT 500L Wagon FIAT 500L Cross	 5	 09/12 → 12/22 07/13 → 05/17 11/13 → 05/17 06/17 → 03/21 06/17 → 12/22	X 31	Y 27	X 39	Y 35
			F 92cm	R 88cm	F 100cm	R 96cm

Front

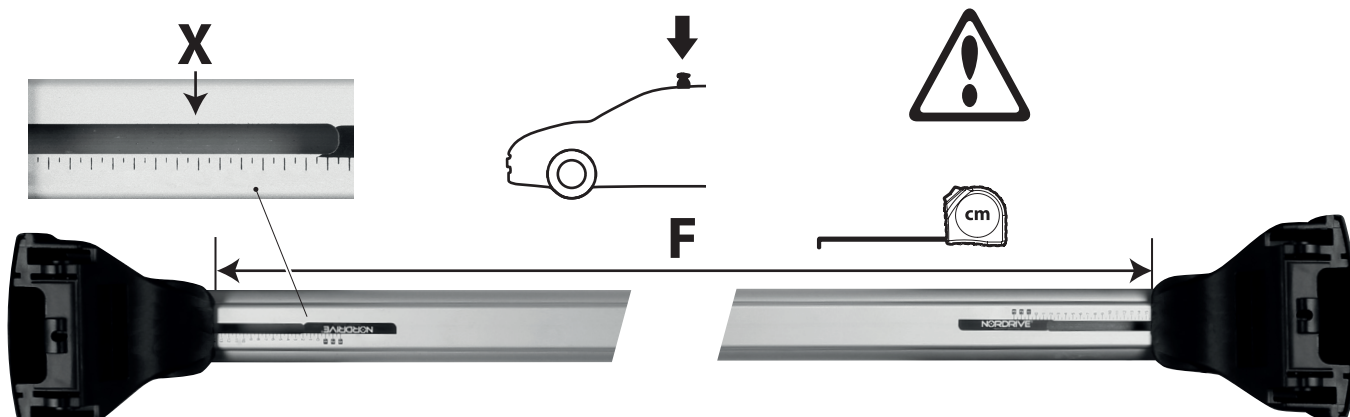

Rear

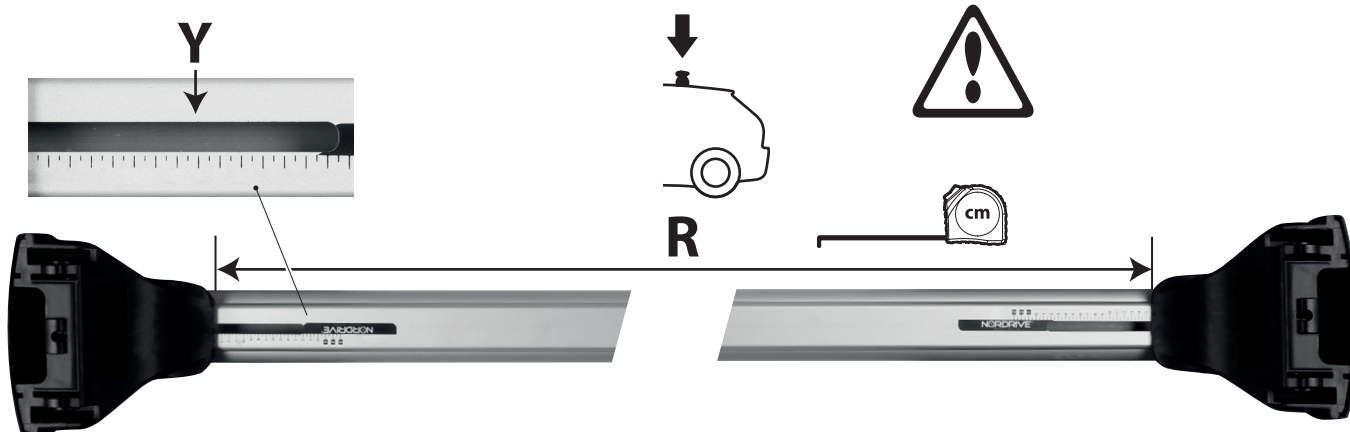

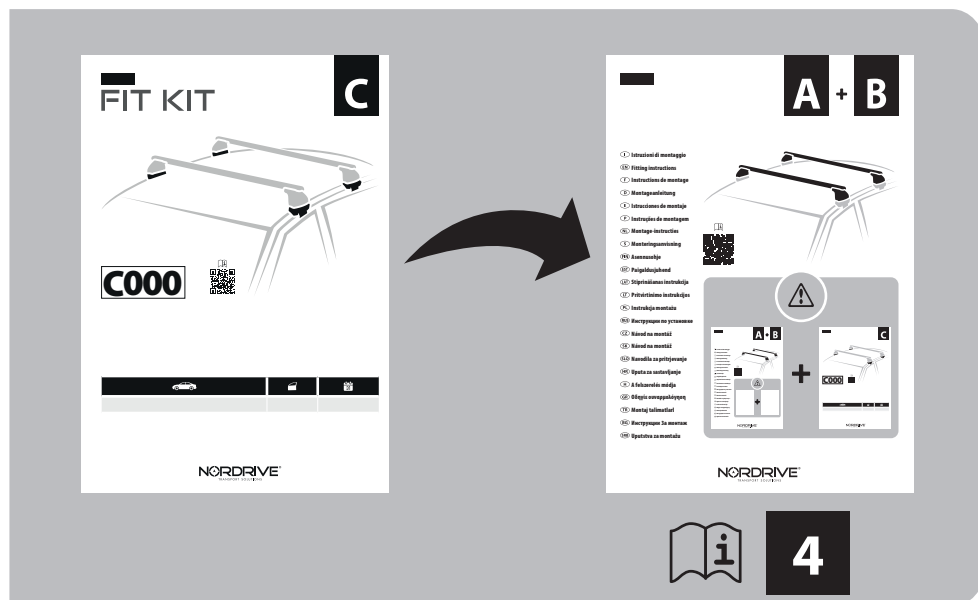

- I** Passare al manuale **A+B** e seguire le istruzioni come indicato ad intestazione pagina.
- EN** Switch to manual **A+B** and then follow the instructions as indicated above.
- F** Passez au manuel **A+B** et suivez les instructions comme indiqué ci-dessus.
- D** Das Handbuch **A+B** konsultieren und die Anleitungen wie angegeben auf Kopfzeile der Seite folgen.
- E** Vaya al manual de **A+B** y siga las instrucciones que se indican en el encabezado de la página.
- P** Passe para o manual **A+B** e siga as instruções indicadas acima.
- NL** Schakel over op manuele **A+B** en volg dan de instructies zoals hierboven aangegeven.
- S** Byt till manual **A+B** och följ där instruktionerna enligt ovan.
- FIN** Vaihdakaanua **A+B** -sarjaan ja noudata sitten yllä olevia ohjeita.
- EST** Avage **A+B** juhend ja järgige ülal toodud juhiseid.
- LAT** Pārslēdzieties uz manuālo **A+B** un pēc tam izpildiet norādījumus, kā norādīts iepriekš.
- LT** Pereikite į vadovą **A+B** ir tuomet sekite instrukcijas, kaip nurodyta aukščiau.

- PL** Przełącz na ręczny **A+B**, a następnie postępuj zgodnie z instrukcjami, jak wskazano powyżej.
- RUS** Перейдите к руководству по **A+B** и следуйте инструкциям, указанным в заголовке страницы.
- CZ** Přejděte do příručky **A+B** a postupujte podle pokynů uvedených v záhlaví stránky.
- SK** Prejdite na návod **A+B** a postupujte podľa pokynov uvedených vyššie.
- SLO** Zamenjajte na navodila **A+B** in potem jim sledite kot je navedeno zgoraj.
- HR** Prebacite se na priručnik **A+B** i zatim slijedite gore navedene upute.
- H** Váltson át az **A+B** használati útmutatójára és kövesse a fenti utasításokat.
- GR** Μεταβείτε στο φυλλάδιο του **A+B** και κατόπι ακολουθήστε τις οδηγίες που φαίνονται παραπάνω.
- TR** Manuel **A+B**'ye geçin ve ardından yukarıda belirtilen talimatları izleyin.
- BG** Преминете към ръководството **A+B** и след това следвайте инструкциите по-горе.
- SRB** Pređite na priručnik **A+B** a zatim sledite gore navedena uputstva.

# 6.1

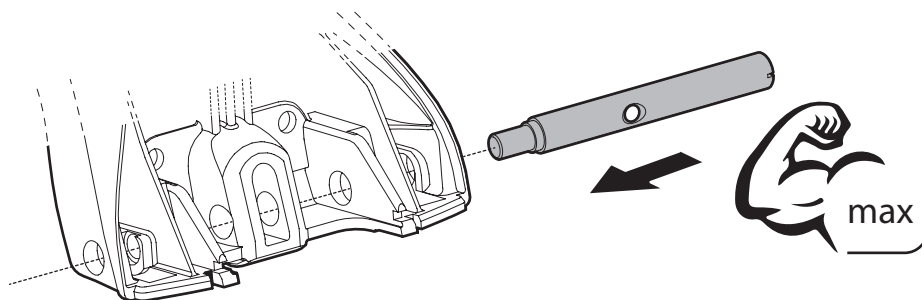

x4

# 6.2

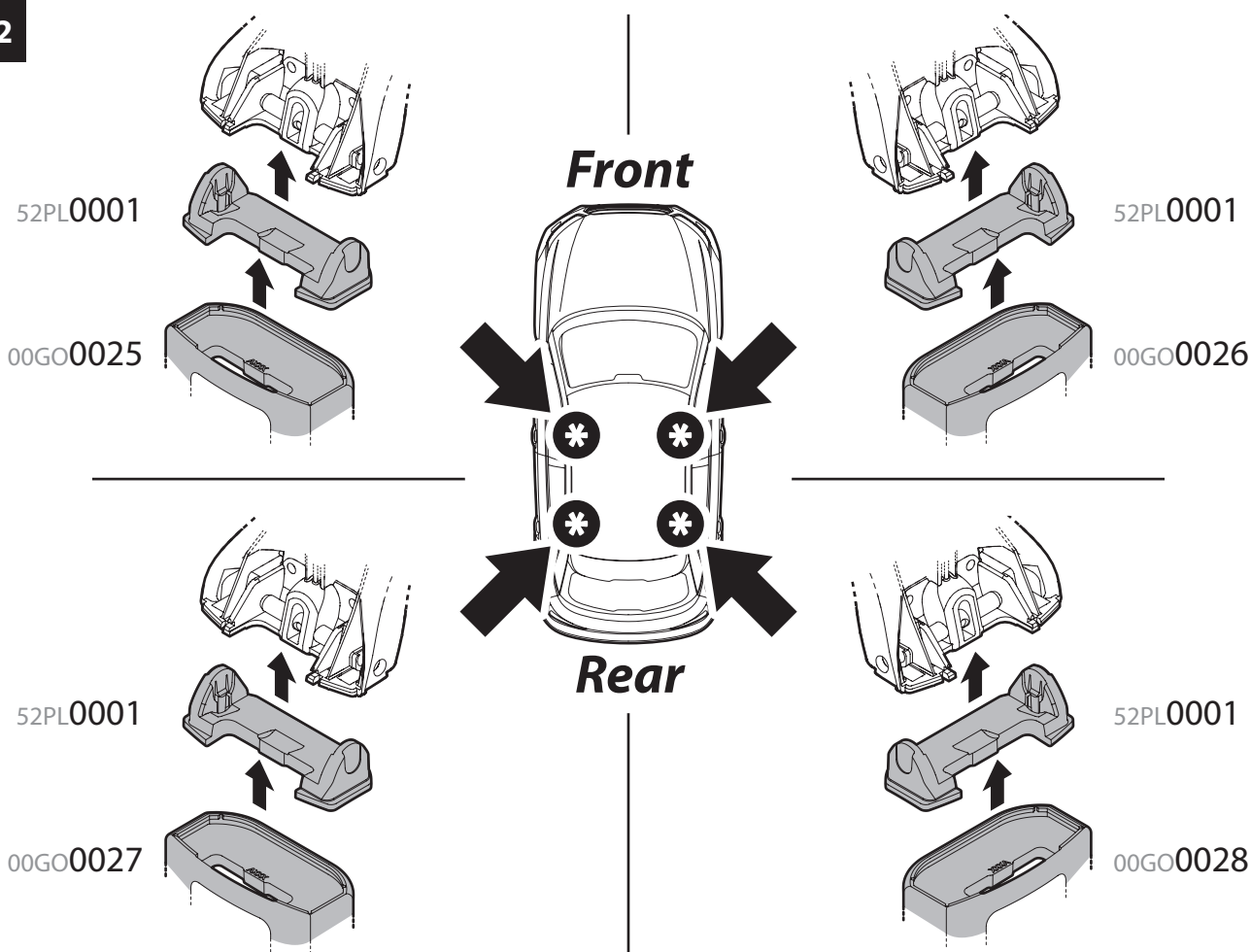

# 6.3

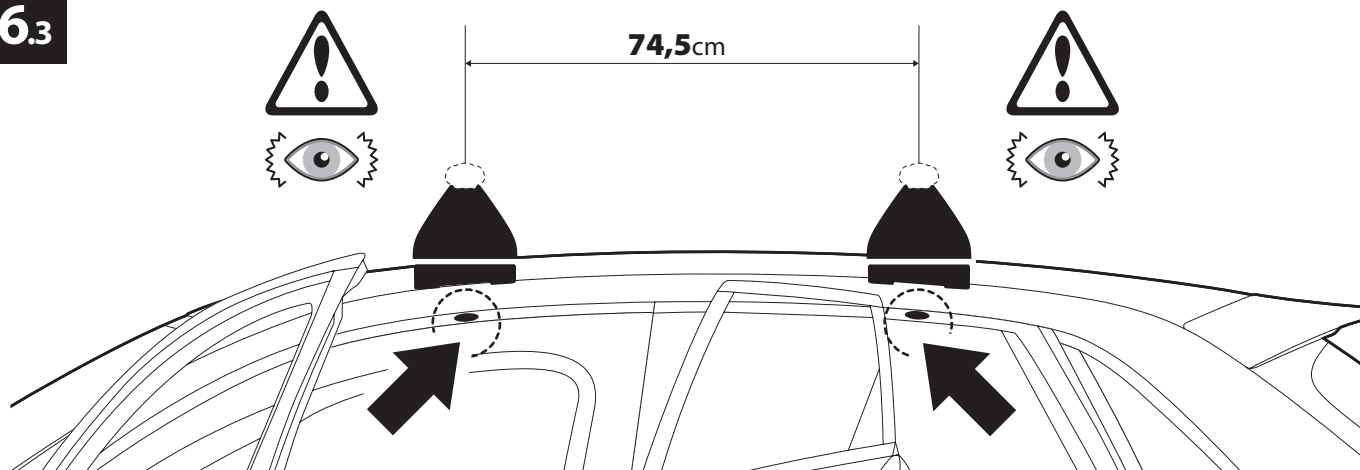

6.4

### Front

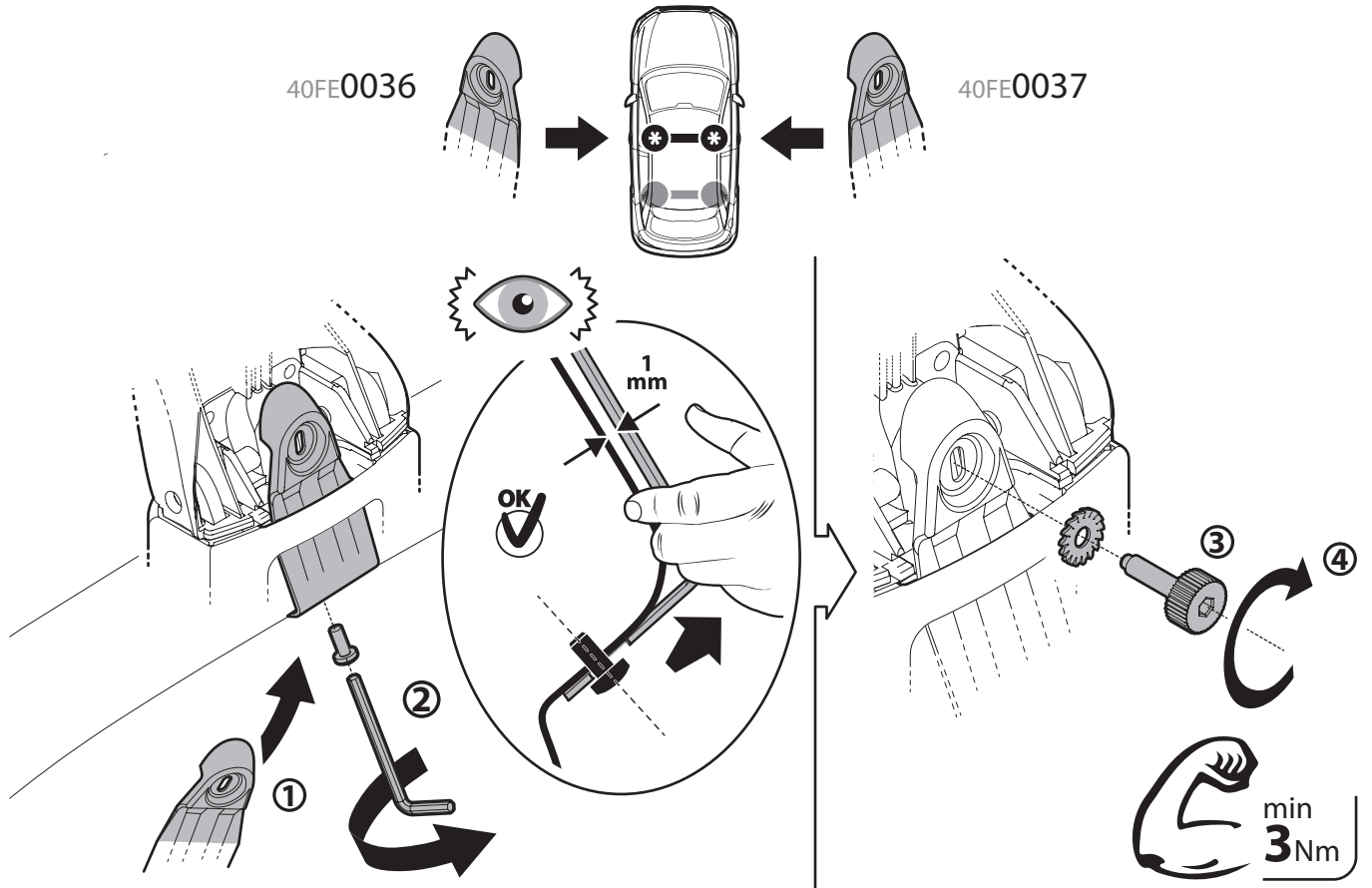

6.5

### Rear

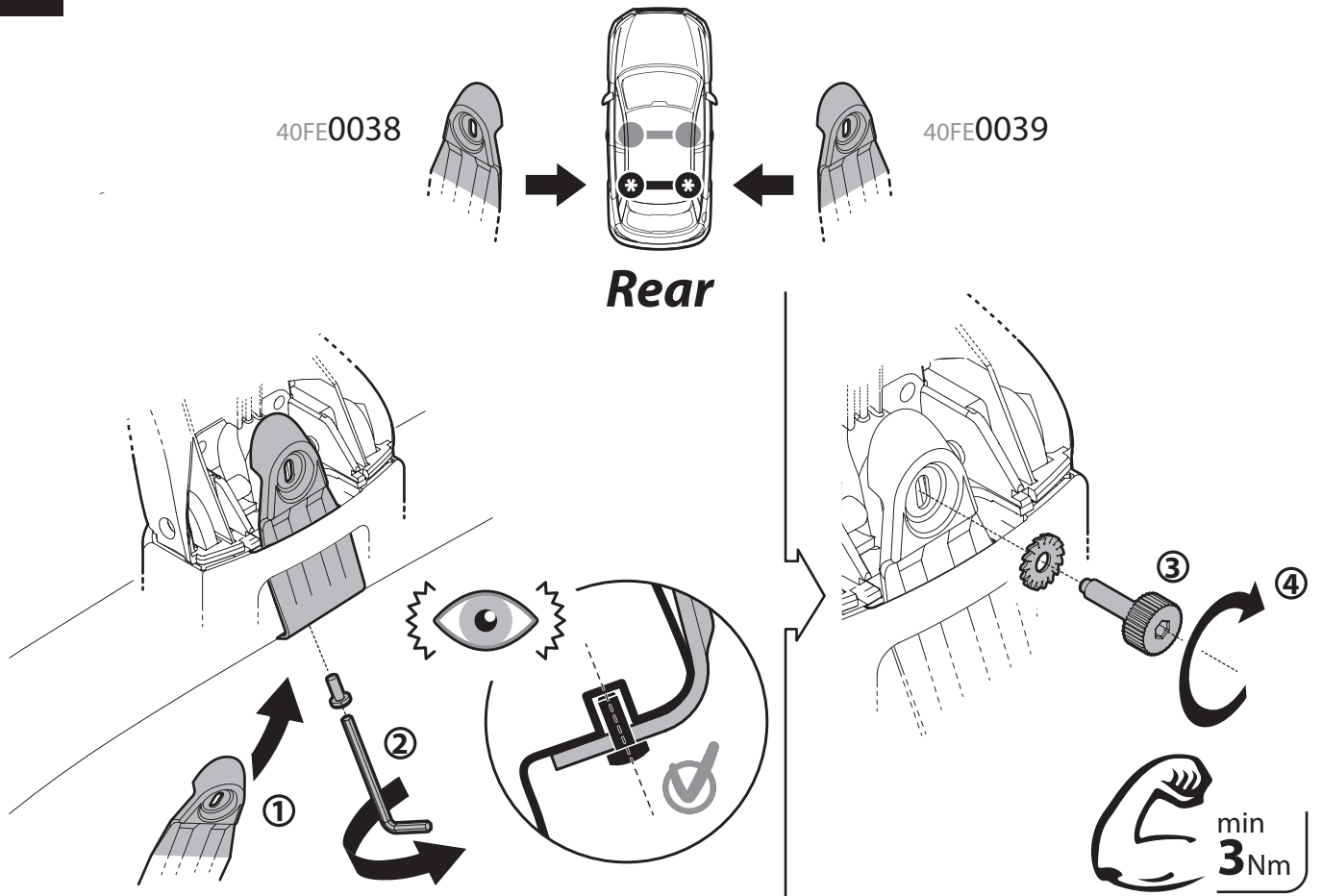

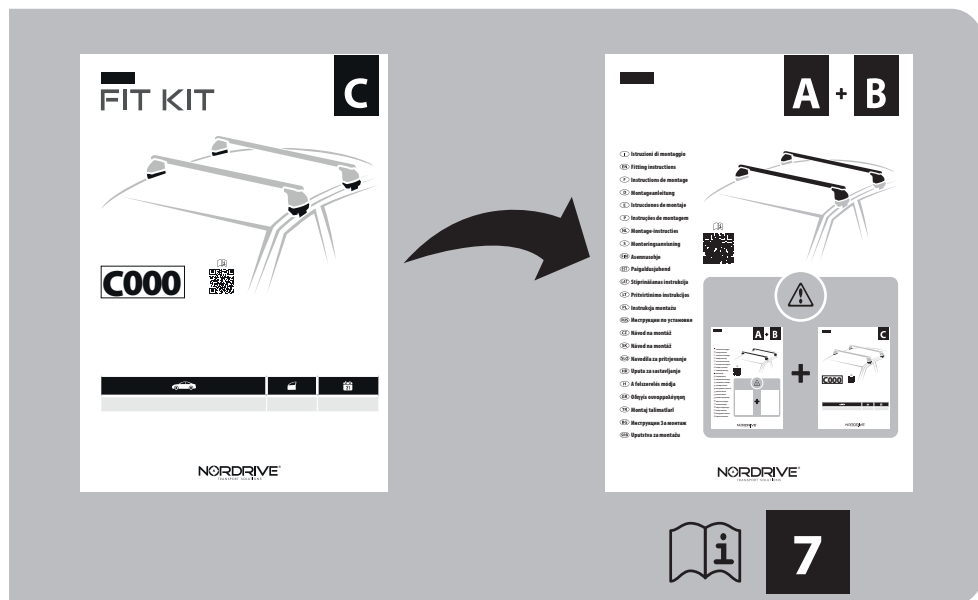

- I** Passare al manuale **A+B** e seguire le istruzioni come indicato ad intestazione pagina.
- EN** Switch to manual **A+B** and then follow the instructions as indicated above.
- F** Passez au manuel **A+B** et suivez les instructions comme indiqué ci-dessus.
- D** Das Handbuch **A+B** konsultieren und die Anleitungen wie angegeben auf Kopfzeile der Seite folgen.
- E** Vaya al manual de **A+B** y siga las instrucciones que se indican en el encabezado de la página.
- P** Passe para o manual **A+B** e siga as instruções indicadas acima.
- NL** Schakel over op manuele **A+B** en volg dan de instructies zoals hierboven aangegeven.
- S** Byt till manual **A+B** och följ där instruktionerna enligt ovan.
- FIN** Vaihda manuaaliseen **A+B** -sarjaan ja noudata sitten yllä olevia ohjeita.
- EST** Avage **A+B** juhend ja järgige ülal toodud juhiseid.
- LAT** Pārslēdzieties uz manuālo **A+B** un pēc tam izpildiet norādījumus, kā norādīts iepriekš.
- LT** Pereikite į vadovą **A+B** ir tuomet sekite instrukcijas, kaip nurodyta aukščiau.

- PL** Przełącz na ręczny **A+B**, a następnie postępuj zgodnie z instrukcjami, jak wskazano powyżej.
- RUS** Перейдите к руководству по **A+B** и следуйте инструкциям, указанным в заголовке страницы.
- CZ** Přejděte do příručky **A+B** a postupujte podle pokynů uvedených v záhlaví stránky.
- SK** Prejdite na návod **A+B** a postupujte podľa pokynov uvedených vyššie.
- SLO** Zamenjajte na navodila **A+B** in potem jim sledite kot je navedeno zgoraj.
- HR** Prebacite se na priručnik **A+B** i zatim slijedite gore navedene upute.
- H** Váltson át az **A+B** használati útmutatójára és kövesse a fenti utasításokat.
- GR** Μεταβείτε στο φυλλάδιο του **A+B** και κατόπιν ακολουθήστε τις οδηγίες που φαίνονται παραπάνω.
- TR** Manuel **A+B**'ye geçin ve ardından yukarıda belirtilen talimatları izleyin.
- BG** Преминете към ръководството **A+B** и след това следвайте инструкциите по-горе.
- SRB** Pređite na priručnik **A+B** a zatim sledite gore navedena uputstva.

- I** Lotto di produzione da comunicare per eventuali ricambi
- EN** Production lot number to be communicated for any spare parts
- F** Lot de production à communiquer pour toute pièce de rechange
- D** Produktionscharge für eventuelle Ersatzteile
- E** Lote de producción a comunicar por cualquier repuesto

**Lot.**

**NORDRIVE®**  
TRANSPORT SOLUTIONS

**NORDRIVE® is a registered trademark of LAMPA S.p.A.**

Via G. Rossa 53/55, 46019 Viadana (MN) ITALY

Tel. +39 0375 820700

UNI EN ISO 9001:2015 Certified Company  
service@lampa.it

[www.nordrive.it](http://www.nordrive.it) [www.lampa.it](http://www.lampa.it)