

FIT KIT

F

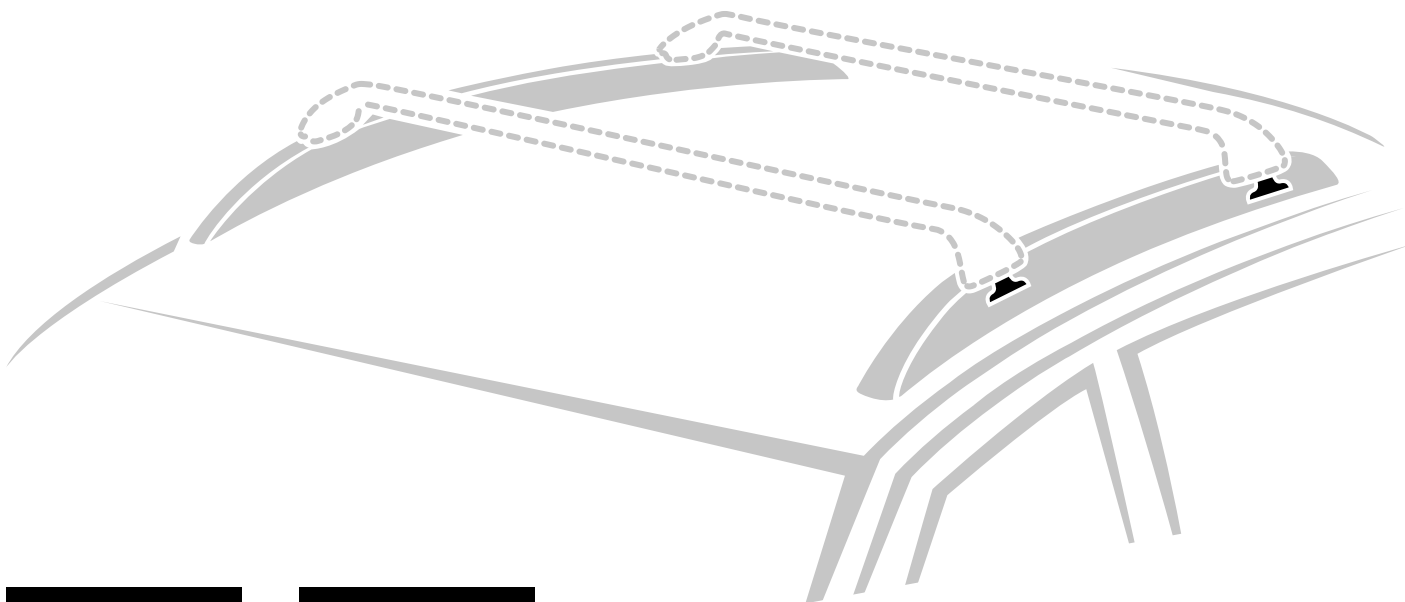

N21402

F2

N21403

F3



Max
75 Kg.



91CA0149 r01

- | | | | |
|-----------------------------------|--------------------------------------|-------------------------------------|---------------------------------|
| I Istruzioni di montaggio | NL Montage-instructies | PL Instrukcja montażu | H A felszerelés módja |
| EN Fitting instructions | S Monteringsanvisning | RUS Инструкции по установке | GR Οδηγία συναρμολόγησης |
| F Instructions de montage | FIN Asennusohje | CZ Návod na montáž | TR Montaj talimatları |
| D Montageanleitung | EST Paigaldusjuhend | SK Návod na montáž | BG Инструкции за монтаж |
| E Instrucciones de montaje | LAT Stiprināšanas instrukcija | SLO Navodila za pritrjevanje | SRB Uputstva za montažu |
| P Instruções de montagem | LT Pritvirtinimo instrukcijos | HR Uputa za sastavljanje | |

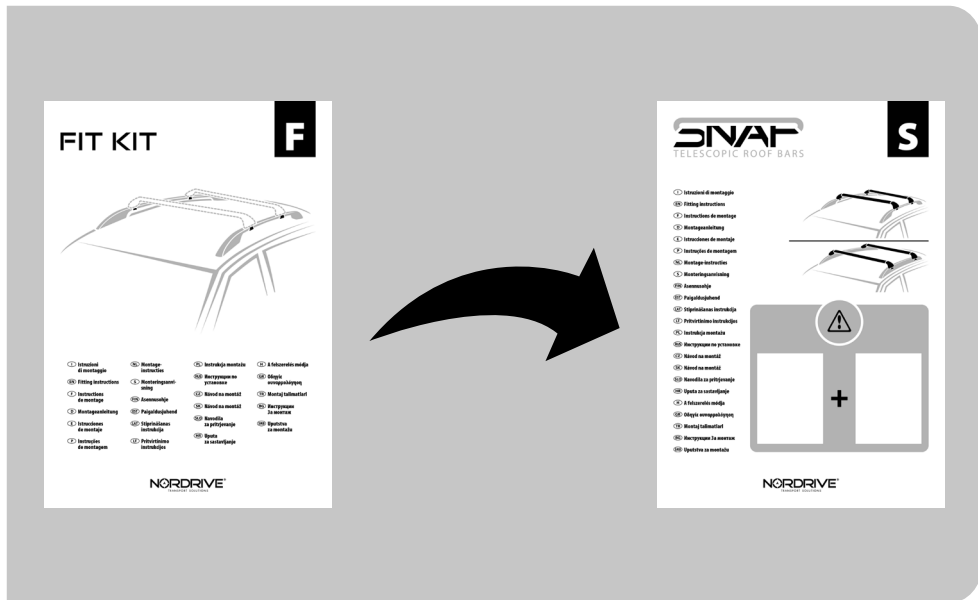

- I** Iniziare dal manuale **S** prima di proseguire con queste istruzioni.
- EN** Before following these instructions **S**, please start firstly the manual.
- F** Avant de suivre ces instructions **S**, veuillez commencer par le manuel.
- D** Lesen Sie zuerst die Anleitung von **S**, bevor Sie die folgende Anweisung weiterlesen.
- E** Inicie desde el manual de **S** antes de continuar con estas instrucciones.
- P** Antes de seguir estas instruções **S**, leia o manual.
- NL** Voordat u deze instructies **S** volgt, dient u eerst de handleiding te starten.
- S** Innan ni följer dessa instruktioner **S**, vänligen läs manualen.
- FIN** Aloita **S**-oppaasta, ennen kuin jatkat näiden ohjeiden noudattamista.
- EST** Enne nende juhiste **S** järgimist alustage kõigepealt kasutusjuhendit.
- LAT** Pirms izpildāt šos norādījumus **S**, lūdzu, vispirms sāciet rokasgrāmatu.
- LT** Prieš pradėdant sekti šias instrukcijas **S**, prašome perskaityti vadovą.

- PL** Przed wykonaniem tych instrukcji **S** należy najpierw zapoznać się z instrukcją.
- RUS** Прежде чем приступить к выполнению этих инструкций **S**, начните с руководства.
- CZ** Než budete pokračovat v těchto pokynech **S**, začněte od manuálu.
- SK** Predtým ako budete postupovať podľa návodu **S**, prosím prečítajte návod.
- SLO** Pred vykonaním týchto pokynov **S** najskôr spustite priročku.
- HR** Prije upotrebe ovih uputa **S**, prvo pokrenite priručnik.
- H** Mielőtt követné ezt az utasítást **S**, olvassa el az használati útmutatóját.
- GR** Διαβάστε τις οδηγίες του **S** προτού ακολουθήσετε αυτές τις οδηγίες.
- TR** Bu talimatları uygulamadan önce, lütfen öncelikle **S** kılavuzunu başlatın.
- BG** Преди да следвате тези инструкции, прочетете ръководството на **S**.
- SRB** Pre nego što sledite ova uputstva, molimo vas pročitajte priručnik **S**.



**N21402 - F2
N21403 - F3** **FIT KIT**

Contenuto • Content • Contenu • Inhalt • Contenido

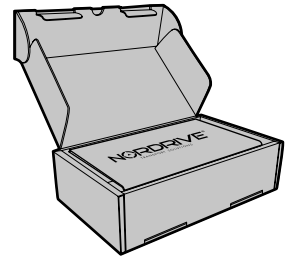

x4

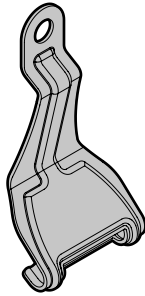

F2

33FE0004

x4

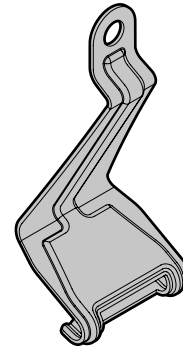

F3

33FE0005

x4

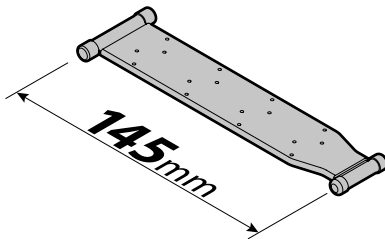

43AX0011

x4

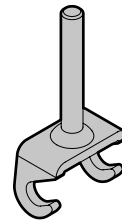

84FE0001

x4



84FE0001

x4

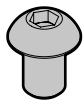

60BE8012

x4



60BE8012

x1

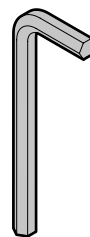

72FE0002

SNAP — STEEL —

Art. N15010 **S** 5,5Kg.

Art. N15012 **L** 6,3Kg.

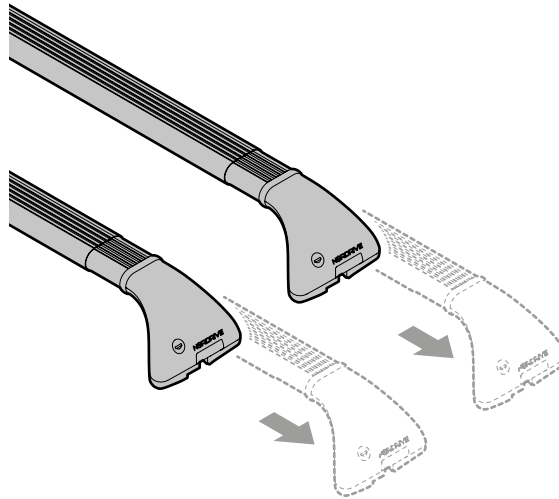

SNAP STEEL RAIL

Art. N15014 **S** 5,8Kg.

Art. N15016 **L** 6,6Kg.

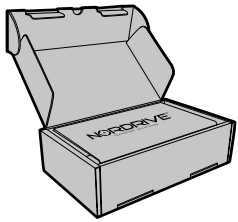

+

F2 | **F3**
0,7Kg. | 0,7Kg.

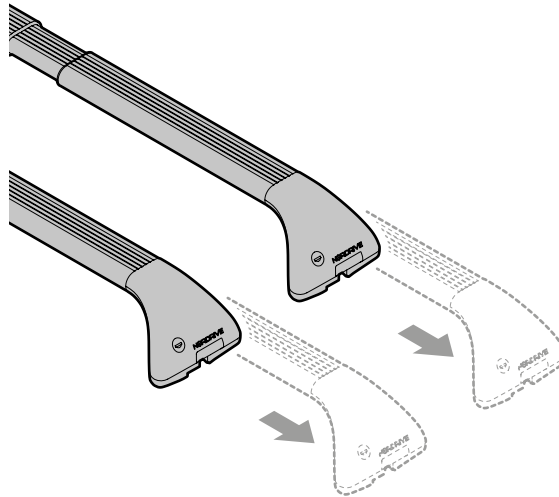

SNAP — ALU —

Art. N15011 **S** 3,4Kg.

Art. N15013 **L** 3,8Kg.

SNAP ALU RAIL

Art. N15015 **S** 3,7Kg.

Art. N15017 **L** 4,1Kg.

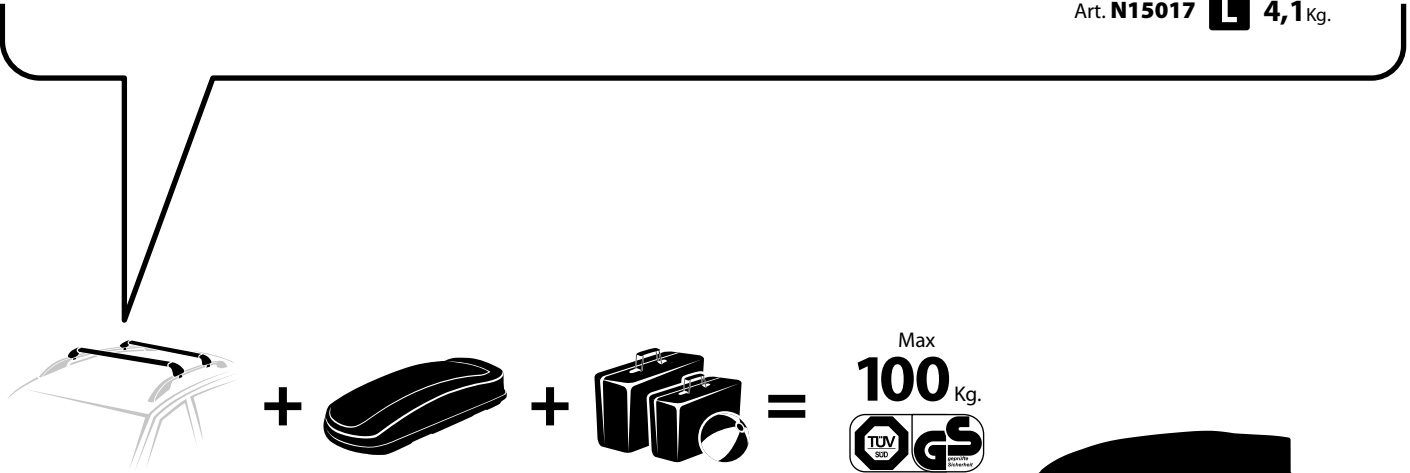

max
kg. ??

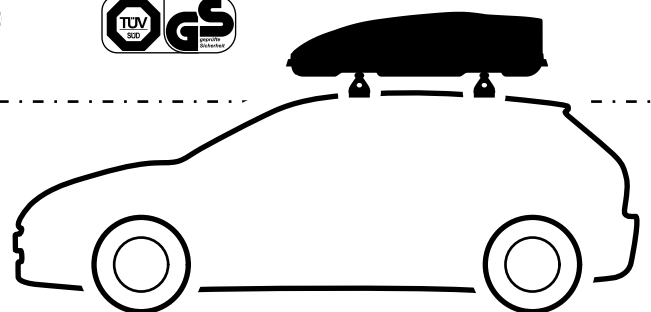



2.1

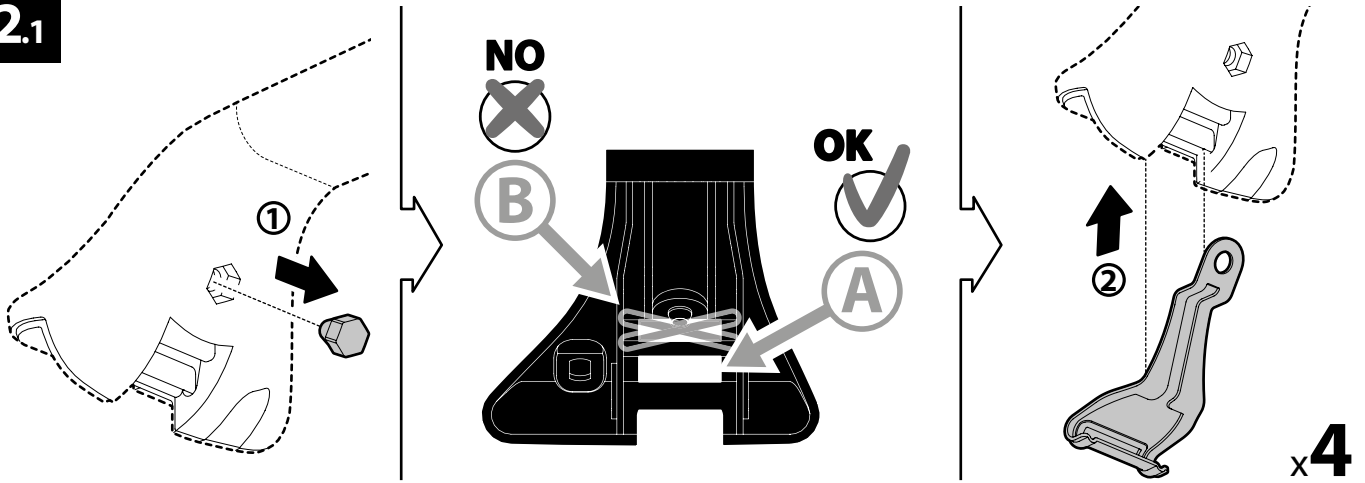

2.2

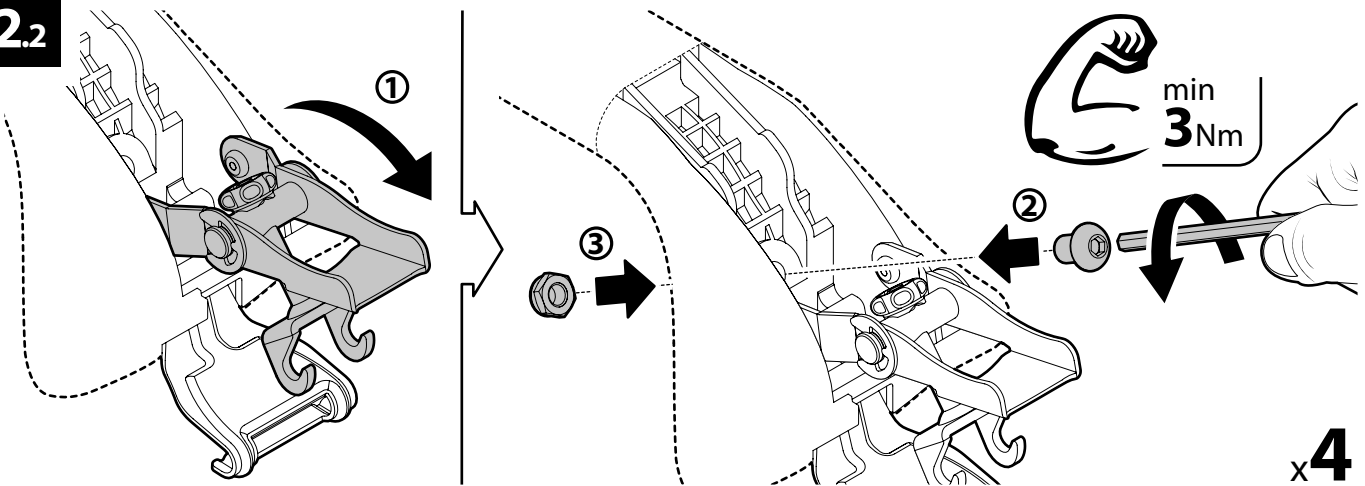

2.3

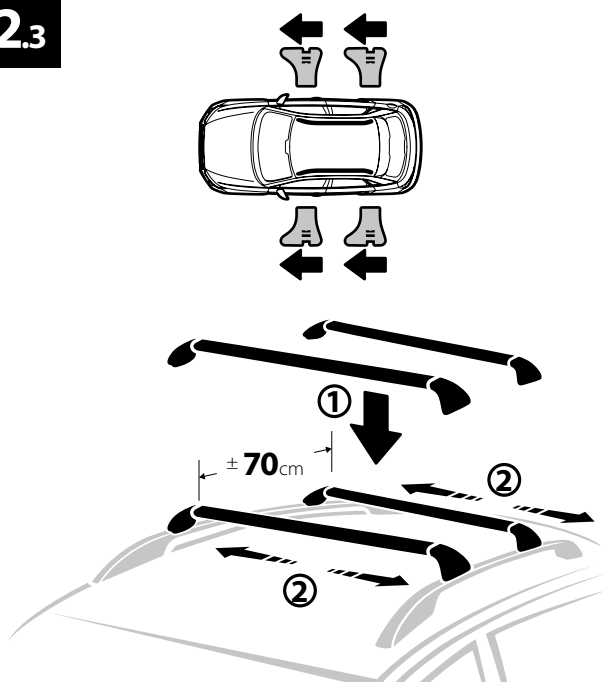

F2

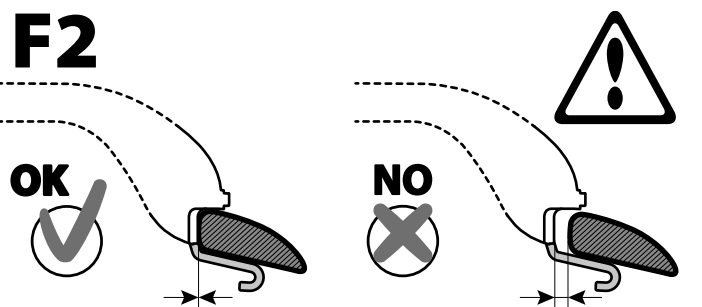

F3

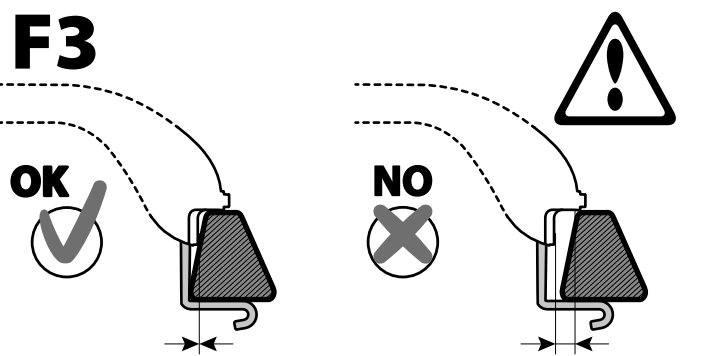

2.4

- ① Per
- ② Für
- ③ For
- ④ Para
- ⑤ Pour

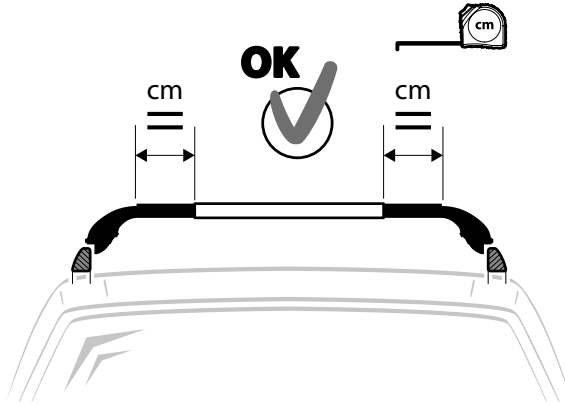

OK

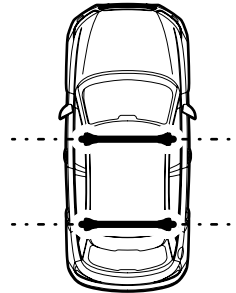

NO

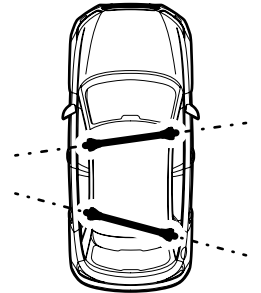

2.5

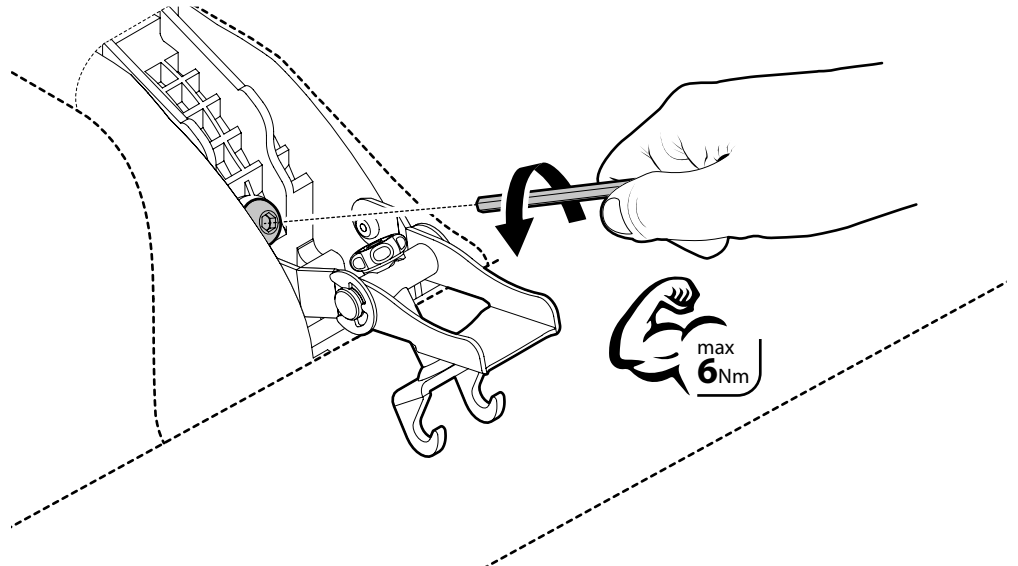
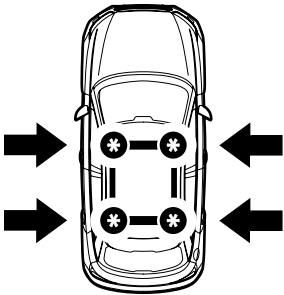

2.6

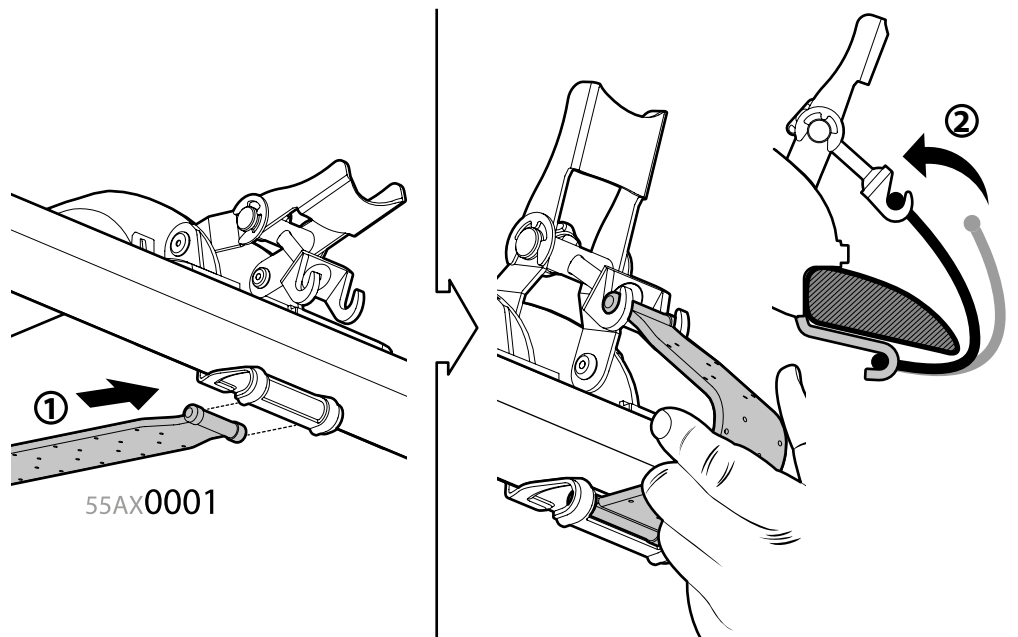
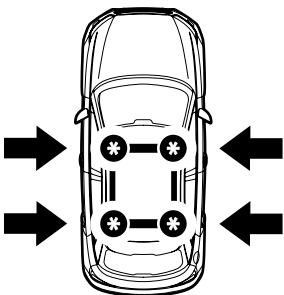

2.7

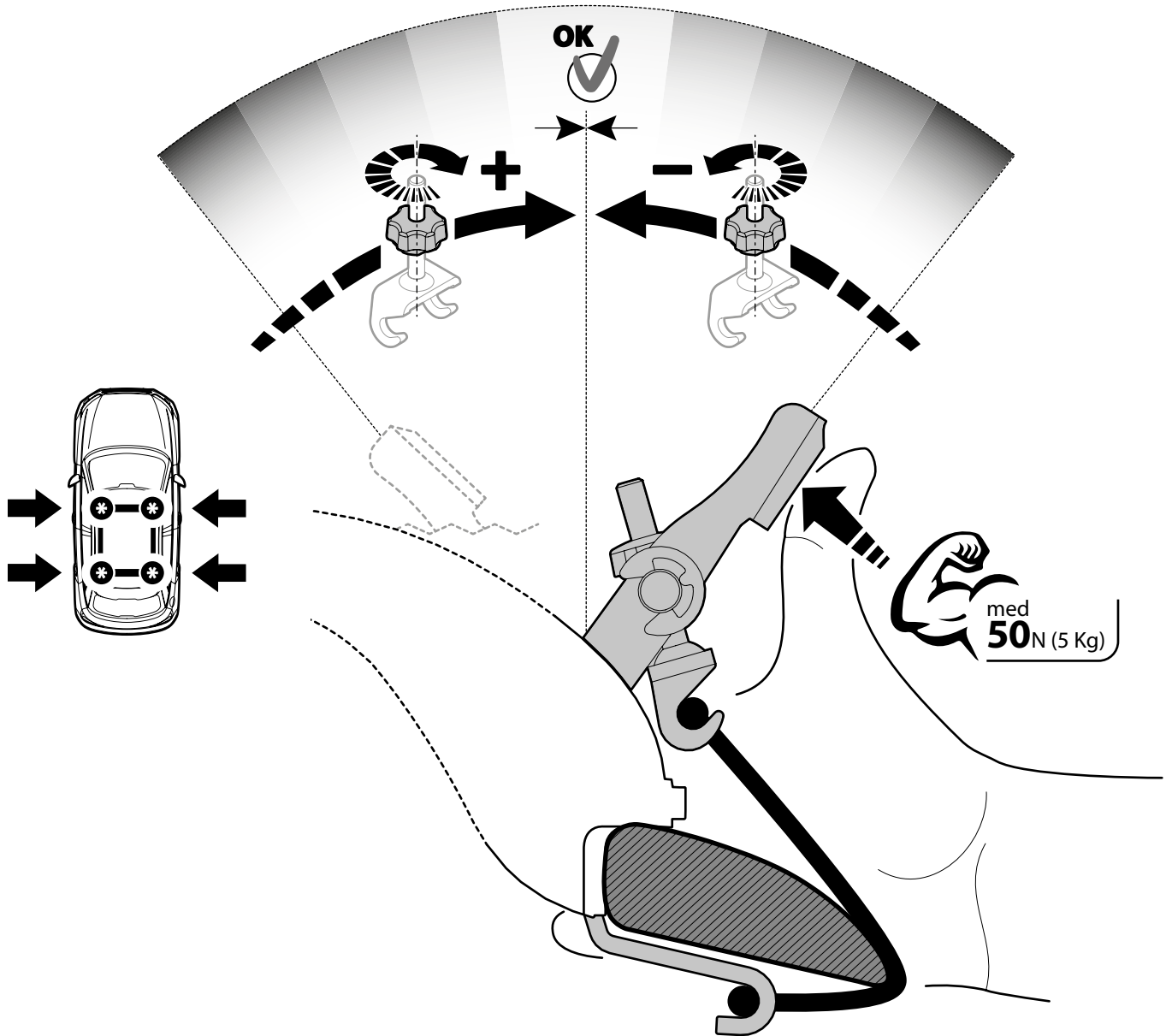

2.8

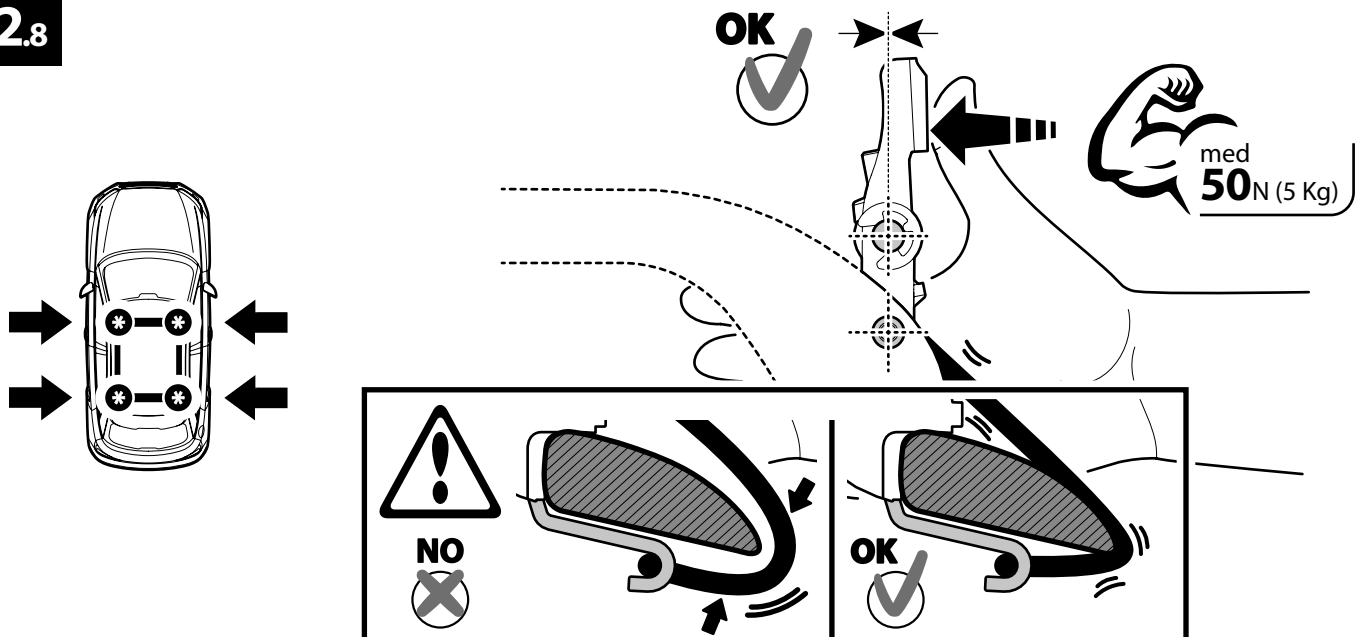

2.9

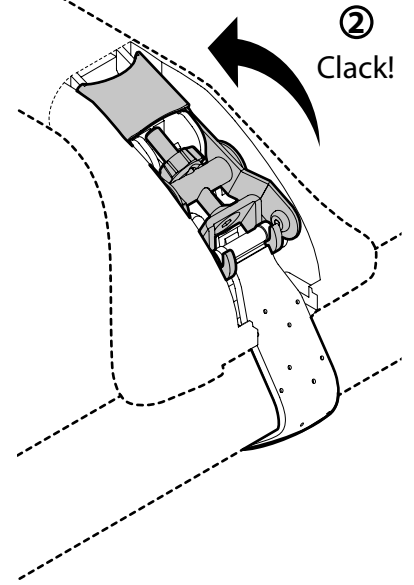
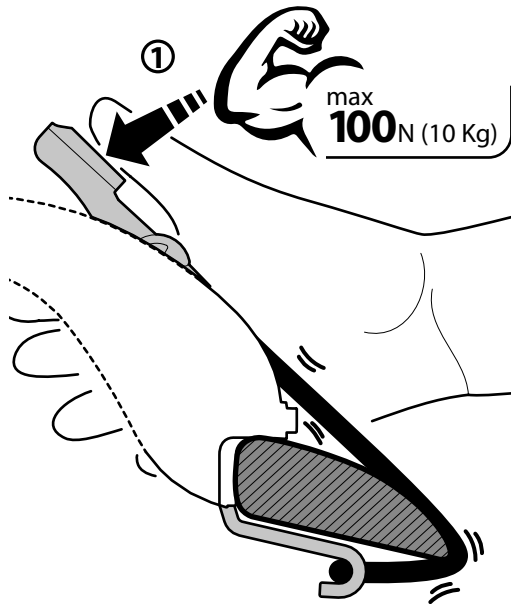
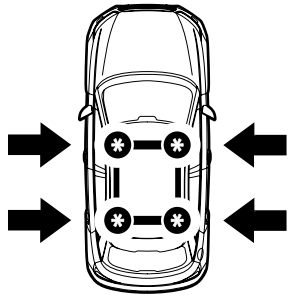



Attenzione • Warning • Attention • Hinweise • Advertencia

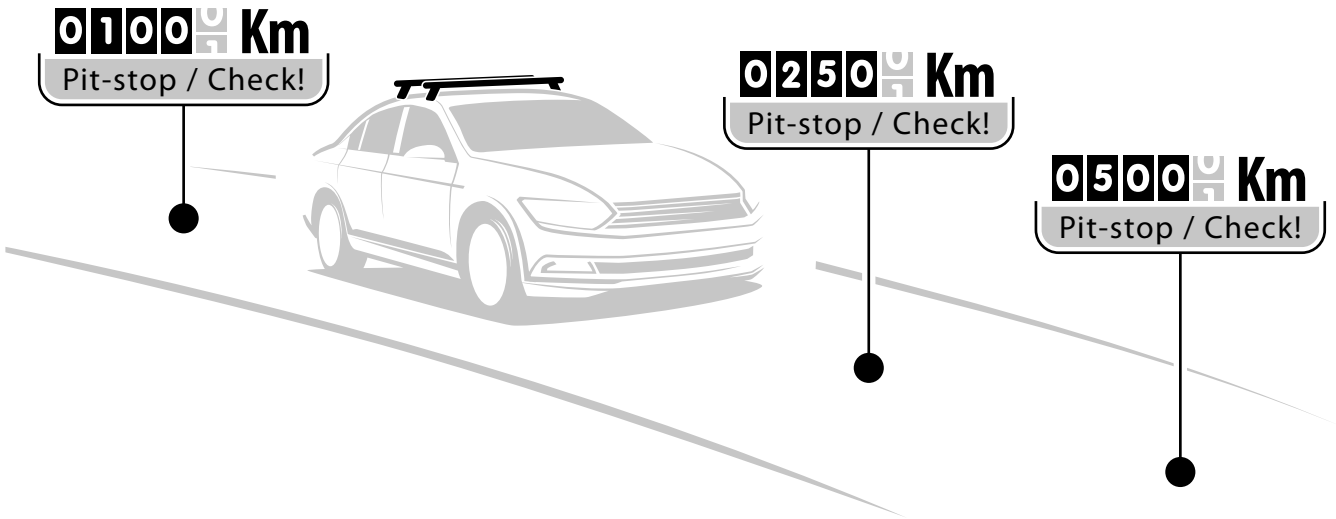

Pit-stop / Check!

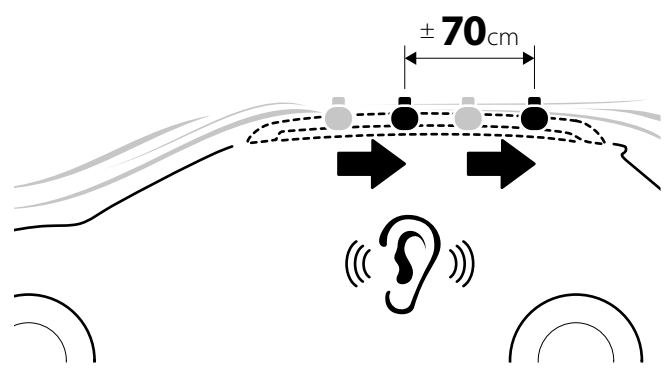
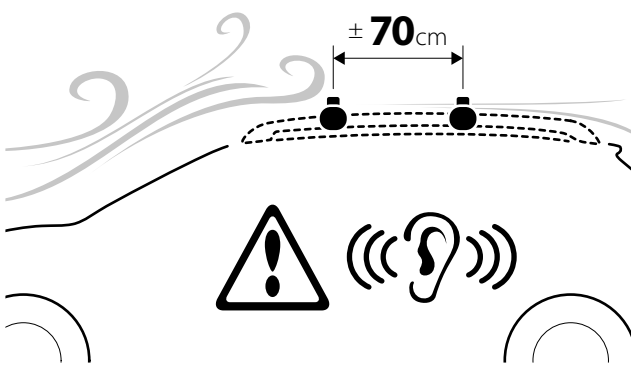
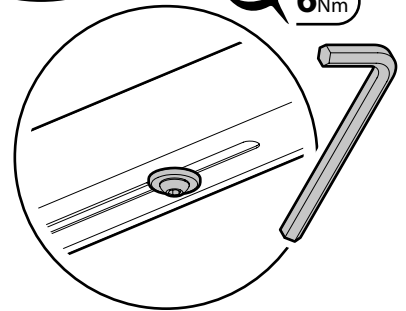
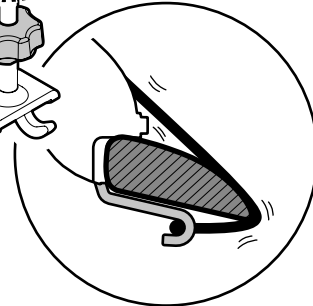
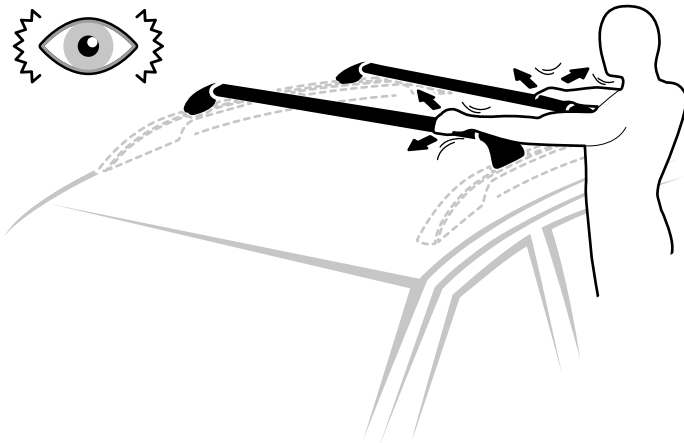

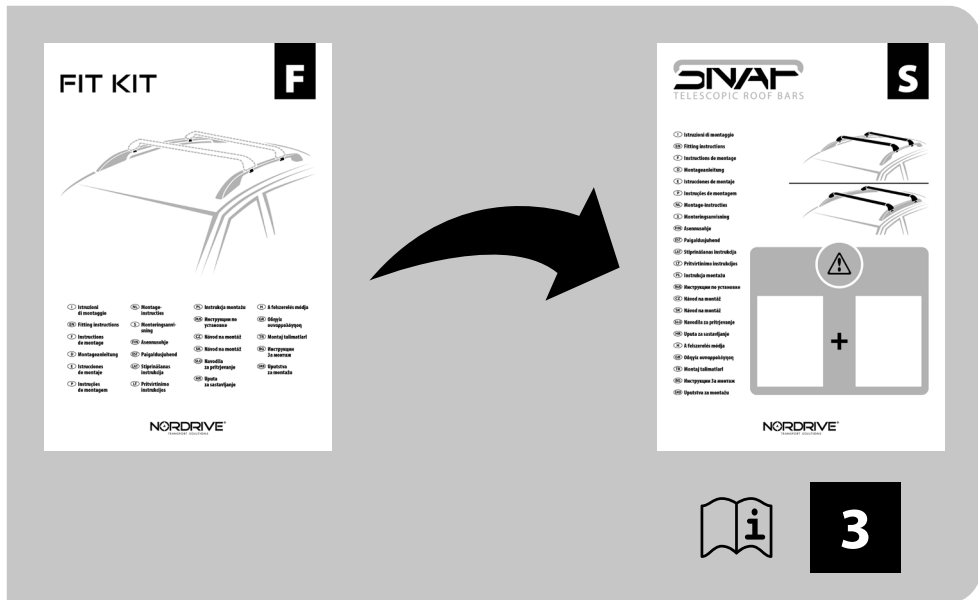

- I** Passare al manuale **S** e seguire le istruzioni come indicato ad intestazione pagina.
- EN** Switch to manual **S** and then follow the instructions as indicated above.
- F** Passez au manuel **S** et suivez les instructions comme indiqué ci-dessus.
- D** Das Handbuch **S** konsultieren und die Anleitungen wie angegeben auf Kopfzeile der Seite folgen.
- E** Vaya al manual de **S** y siga las instrucciones que se indican en el encabezado de la página.
- P** Passe para o manual **S** e siga as instruções indicadas acima.
- NL** Schakel over op manuele **S** en volg dan de instructies zoals hierboven aangegeven.
- S** Byt till manual **S** och följ där instruktionerna enligt ovan.
- FIN** Vaihda manuaaliseen **S** -sarjaan ja noudata sitten yllä olevia ohjeita.
- EST** Avage **S** juhend ja järgige ülal toodud juhiseid.
- LAT** Pārslēdzieties uz manuālo **S** un pēc tam izpildiet norādījumus, kā norādīts iepriekš.
- LT** Pereikite į vadovą **S** ir tuomet sekite instrukcijas, kaip nurodyta aukščiau.

- PL** Przełącz na ręczny **S**, a następnie postępuj zgodnie z instrukcjami, jak wskazano powyżej.
- RUS** Перейдите к руководству по **S** и следуйте инструкциям, указанным в заголовке страницы.
- CZ** Přejděte do příručky **S** a postupujte podle pokynů uvedených v záhlaví stránky.
- SK** Prejdite na návod **S** a postupujte podľa pokynov uvedených vyššie.
- SLO** Zamenjajte na navodila **S** in potem jim sledite kot je navedeno zgoraj.
- HR** Prebacite se na priručnik **S** i zatim slijedite gore navedene upute.
- H** Váltson át az **S** használati útmutatójára és kövesse a fenti utasításokat.
- GR** Μεταβείτε στο φυλλάδιο του **S** και κατόπιν ακολουθήστε τις οδηγίες που φαίνονται παραπάνω.
- TR** Manuel **S**'ye geçin ve ardından yukarıda belirtilen talimatları izleyin.
- BG** Преминете към ръководството **S** и след това следвайте инструкциите по-горе.
- SRB** Pređite na priručnik **S** a zatim sledite gore navedena uputstva.

- ① Lotto di produzione da comunicare per eventuali ricambi
- Ⓞ Production lot number to be communicated for any spare parts
- ⓕ Lot de production à communiquer pour toute pièce de rechange
- ⓓ Produktionscharge für eventuelle Ersatzteile
- ⓔ Lote de producción a comunicar por cualquier repuesto

Lot.

NORDRIVE[®]
TRANSPORT SOLUTIONS

**NORDRIVE[®] is a registered trademark of
LAMPA S.p.A.**

Via G. Rossa 53/55, 46019 Viadana (MN) ITALY
Tel. +39 0375 820700

UNI EN ISO 9001:2015 Certified Company

www.nordrive.it www.lampa.it