

N21221

FIT KIT

C

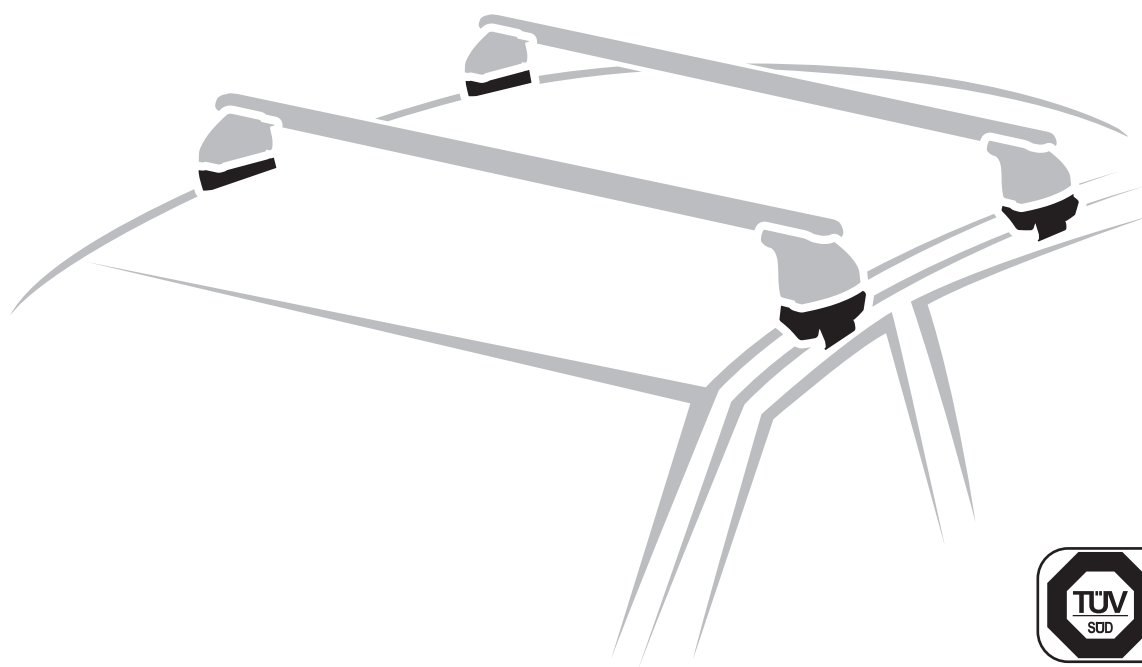

C221

91CA0207 r03

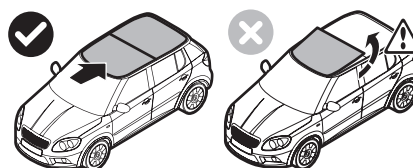

Non aprire
Don't open
Ne pas ouvrir
Öffnen Sie nicht
No abrir

COMPATIBILE PER - COMPATIBLE FOR - COMPATIBLE POUR COMPATIBLE PARA - KOMPATIBEL FÜR			
Mercedes Classe A		5	10/12 → 05/18
Mercedes Classe A		5	06/18 →

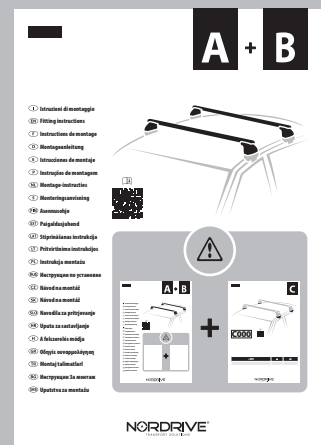
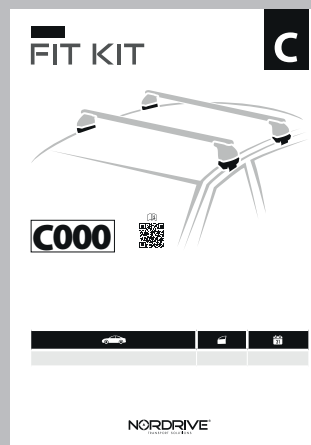

- I** Iniziare dal manuale **A+B** prima di proseguire con queste istruzioni **C**.
- EN** Before following these instructions **C**, please start firstly the manual **A+B**.
- F** Avant de suivre ces instructions **C**, veuillez commencer par le manuel **A+B**.
- D** Lesen Sie zuerst die Anleitung von **A+B**, bevor Sie die folgende Anweisung weiterlesen **C**.
- E** Inicie desde el manual de **A+B** antes de continuar con estas instrucciones **C**.
- P** Antes de seguir estas instruções **C**, leia o manual **A+B**.
- NL** Voordat u deze instructies **C** volgt, dient u eerst de handleiding **A+B** te starten.
- S** Innan ni följer dessa instruktioner **C**, vänligen läs manualen **A+B**.
- FIN** Aloita **A+B** -oppaasta, ennen kuin jatkat näiden ohjeiden noudattamista **C**.
- EST** Enne nende juhiste **C** järgimist alustage kõigepealt **A+B** kasutusjuhendit.
- LAT** Pirms izpildāt šos norādījumus **C**, lūdzu, vispirms sāciet **A+B** rokasgrāmatu.
- LT** Prieš pradėdant sekti šias instrukcijas **C**, prašome perskaityti vadovą **A+B**.

- PL** Przed wykonaniem tych instrukcji **C** należy najpierw zapoznać się z instrukcją **A+B**.
- RUS** Прежде чем приступить к выполнению этих инструкций **C**, начните с руководства **A+B**.
- CZ** Než budete pokračovat v těchto pokynech **C**, začněte od manuálu **A+B**.
- SK** Predtým ako budete postupovať podľa návodu, prosím prečítajte návod **A+B**.
- SLO** Pred vykonaním týchto pokynov **C** najskôr spustite priručku **A+B**.
- HR** Prije upotrebe ovih uputa **C**, prvo pokrenite priručnik **A+B**.
- H** Mielőtt követné ezt az utasítást **C**, olvassa el az **A+B** használati útmutatóját.
- GR** Διαβάστε τις οδηγίες του **A+B** προτού ακολουθήσετε αυτές τις οδηγίες **C**.
- TR** Bu talimatları uygulamadan önce **C**, lütfen öncelikle **A+B** kılavuzunu başlatın.
- BG** Преди да следвате тези инструкции **C**, прочетете ръководството на **A+B**.
- SRB** Pre nego što sledite ova uputstva **C**, molimo vas pročitajte priručnik **A+B**.



C221 FIT KIT

Contenuto • Content • Contenu • Inhalt • Contenido

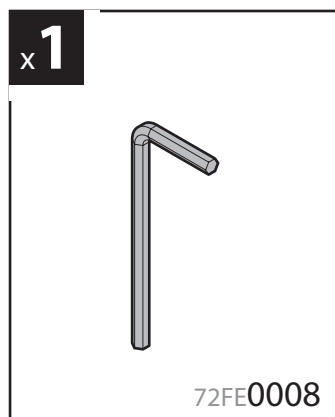
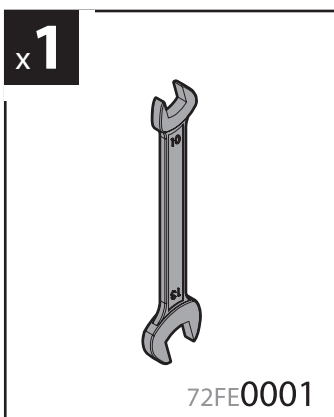
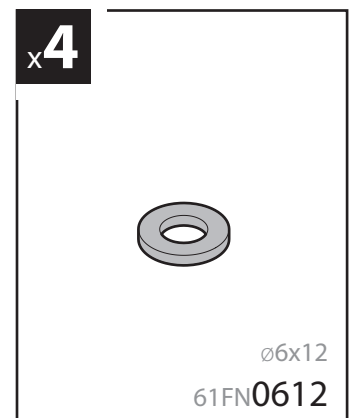
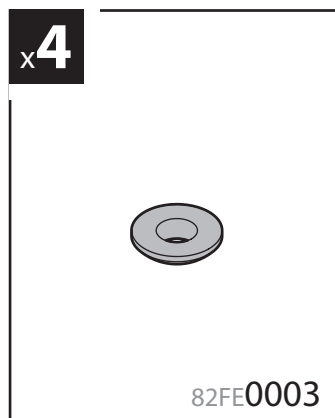
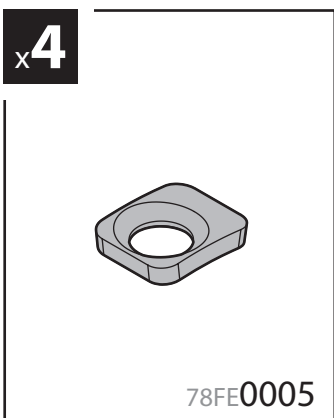
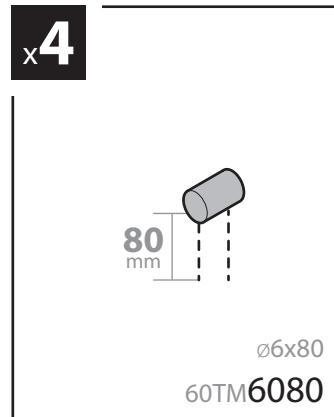
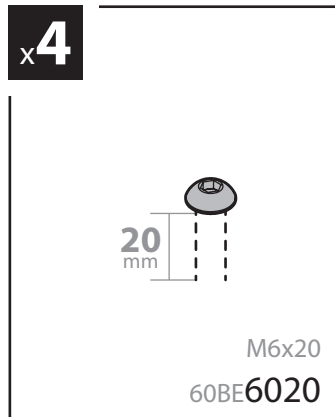
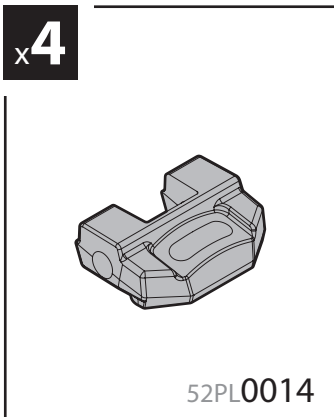
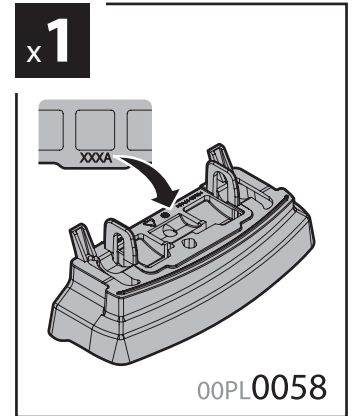
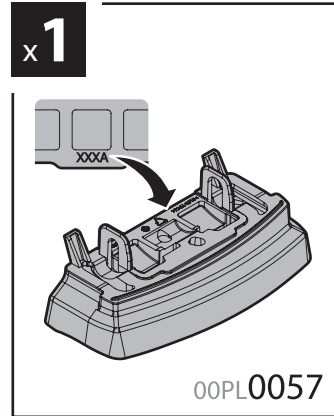
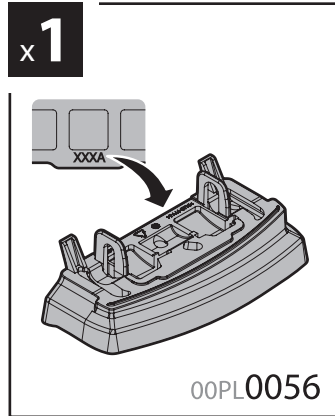
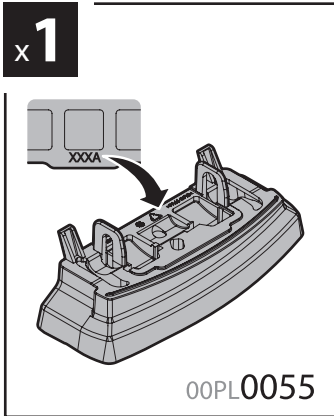
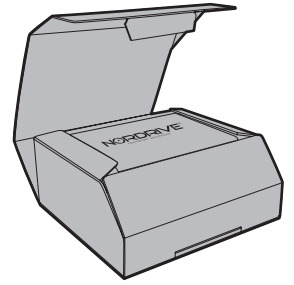

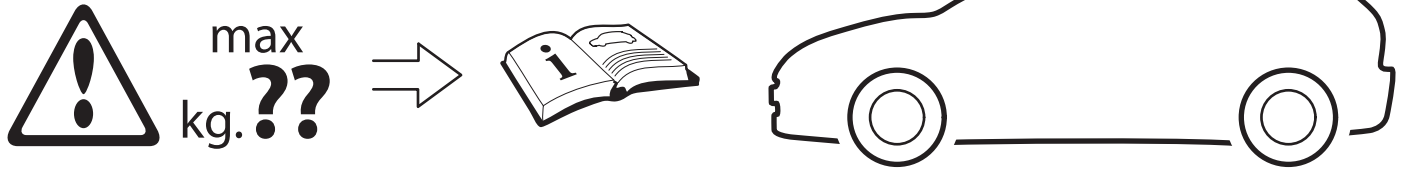

Montaggio • Fitting instructions • Montage • Montageanleitung • Montaje

COMPATIBILE PER - COMPATIBLE FOR - COMPATIBLE POUR - COMPATIBLE PARA - KOMPATIBEL FÜR

3.1

SETTINGS

			EVOS ST STANDARD		EVOS LP LOW PROFILE	
			Front	Rear	Front	Rear
			X 19	Y 12,5	X 27	Y 20,5
Mercedes Classe A	5	10/12 → 05/18	F 80,3cm	R 73,5cm	F 88,3cm	R 81,5cm
Mercedes Classe A	5	06/18 →	X 20	Y 13	X 28	Y 21
			F 80,8cm	R 74cm	F 88,8cm	R 82cm

Front

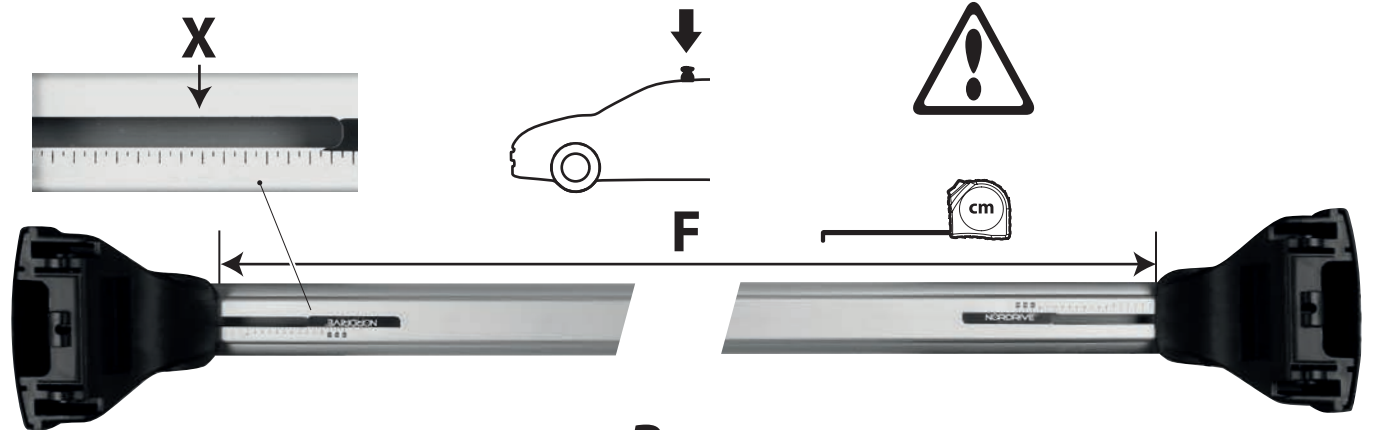

Rear

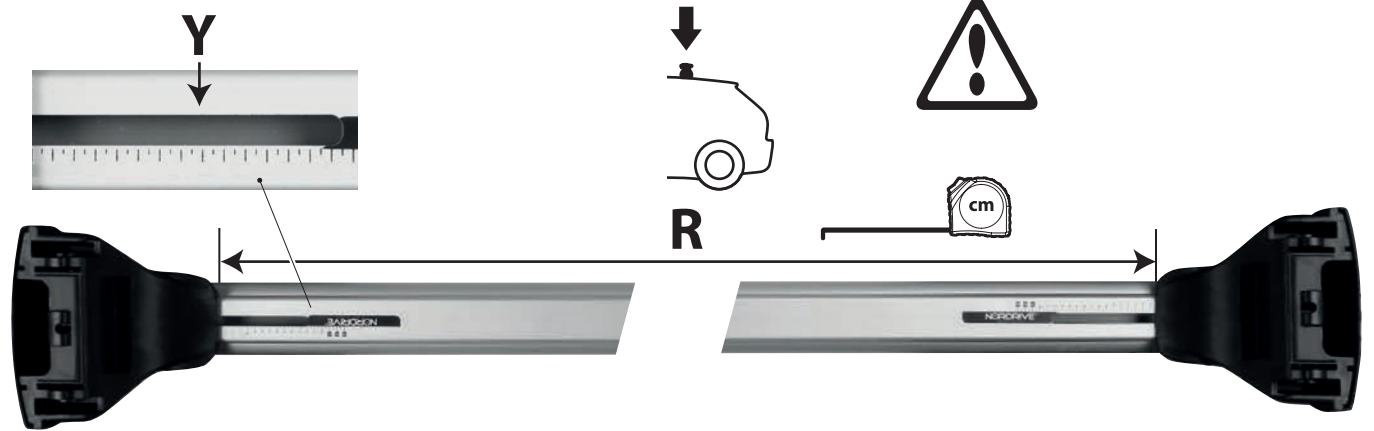

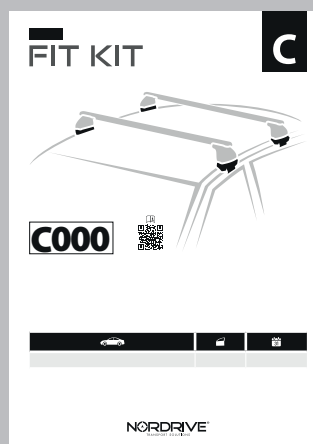

4

- I** Passare al manuale **A+B** e seguire le istruzioni come indicato ad intestazione pagina.
- EN** Switch to manual **A+B** and then follow the instructions as indicated above.
- F** Passez au manuel **A+B** et suivez les instructions comme indiqué ci-dessus.
- D** Das Handbuch **A+B** konsultieren und die Anleitungen wie angegeben auf Kopfzeile der Seite folgen.
- E** Vaya al manual de **A+B** y siga las instrucciones que se indican en el encabezado de la página.
- P** Passe para o manual **A+B** e siga as instruções indicadas acima.
- NL** Schakel over op manuele **A+B** en volg dan de instructies zoals hierboven aangegeven.
- S** Byt till manual **A+B** och följ där instruktionerna enligt ovan.
- FIN** Vaihda manuaaliseen **A+B** -sarjaan ja noudata sitten yllä olevia ohjeita.
- EST** Avage **A+B** juhend ja järgige ülal toodud juhiseid.
- LAT** Pārslēdzieties uz manuālo **A+B** un pēc tam izpildiet norādījumus, kā norādīts iepriekš.
- LT** Pereikite į vadovą **A+B** ir tuomet sekite instrukcijas, kaip nurodyta aukščiau.
- PL** Przełącz na ręczny **A+B**, a następnie postępuj zgodnie z instrukcjami, jak wskazano powyżej.
- RUS** Перейдите к руководству по **A+B** и следуйте инструкциям, указанным в заголовке страницы.
- CZ** Přejděte do příručky **A+B** a postupujte podle pokynů uvedených v záhlaví stránky.
- SK** Prejdite na návod **A+B** a postupujte podľa pokynov uvedených vyššie.
- SLO** Zamenjajte na navodila **A+B** in potem jim sledite kot je navedeno zgoraj.
- HR** Prebacite se na priručnik **A+B** i zatim slijedite gore navedene upute.
- H** Váltson át az **A+B** használati útmutatójára és kövesse a fenti utasításokat.
- GR** Μεταβείτε στο φυλλάδιο του **A+B** και κατόπιν ακολουθήστε τις οδηγίες που φαίνονται παραπάνω.
- TR** Manuel **A+B**'ye geçin ve ardından yukarıda belirtilen talimatları izleyin.
- BG** Преминете към ръководството **A+B** и след това следвайте инструкциите по-горе.
- SRB** Pređite na priručnik **A+B** a zatim sledite gore navedena uputstva.

6.1

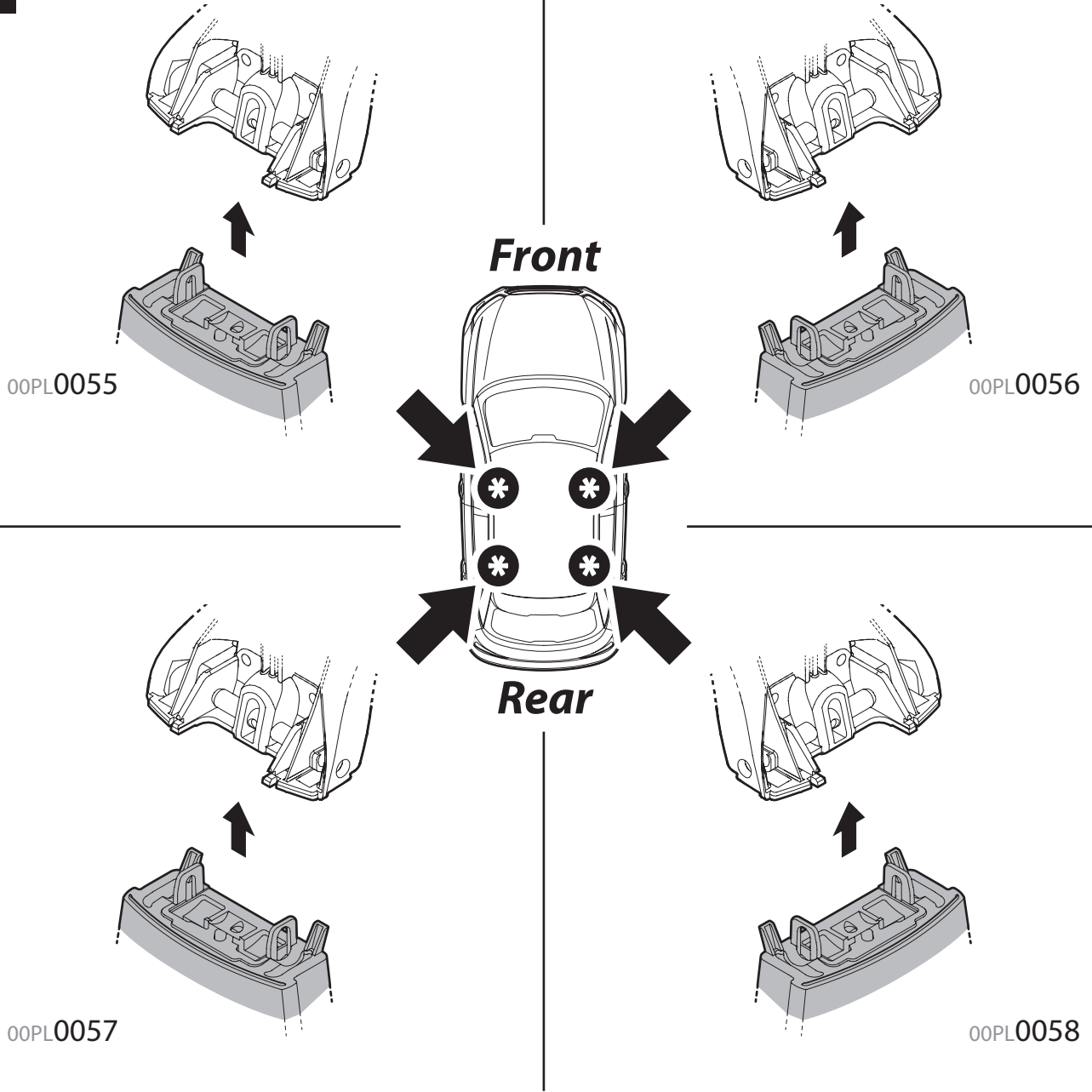

6.2

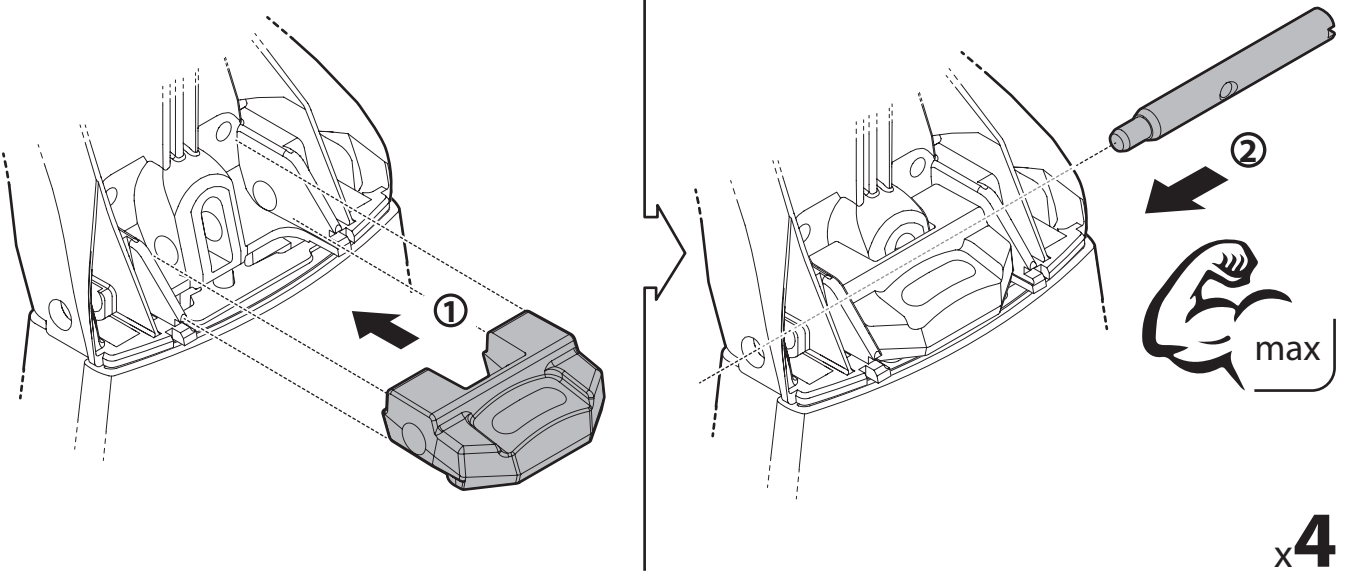

6.3

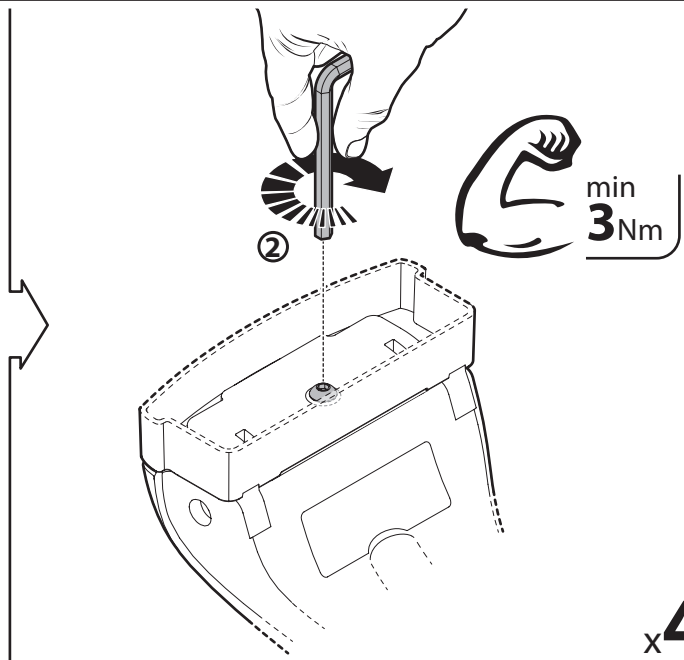
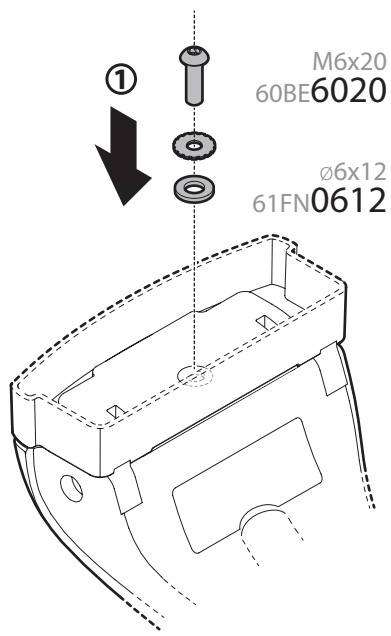

x4

6.4

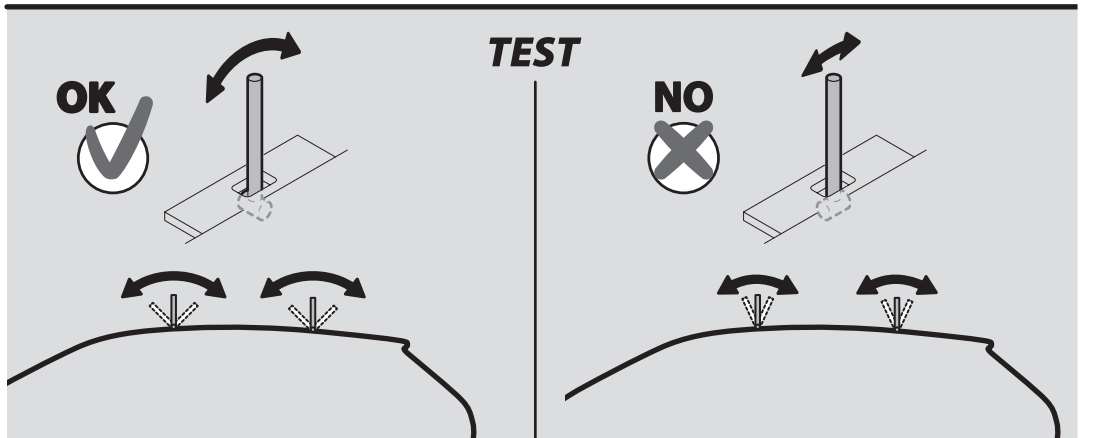
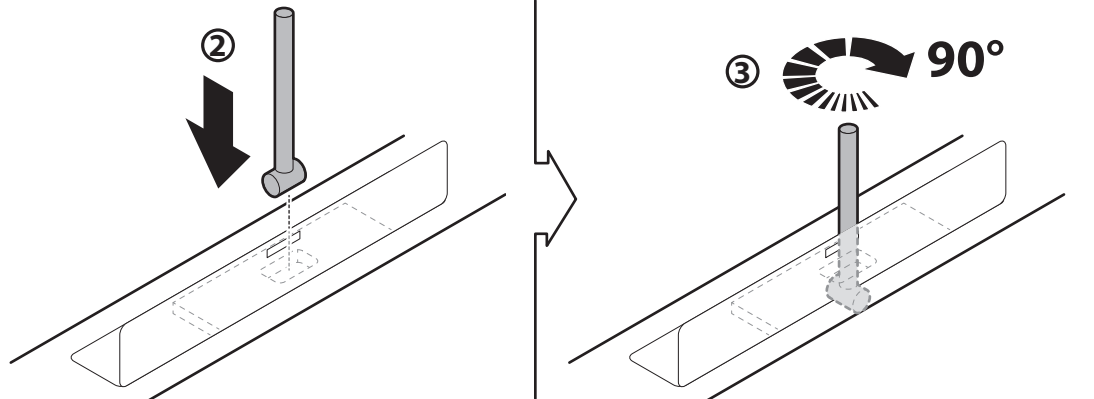
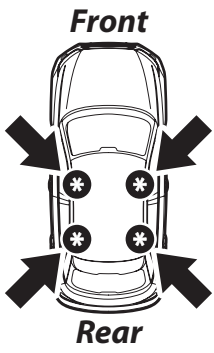
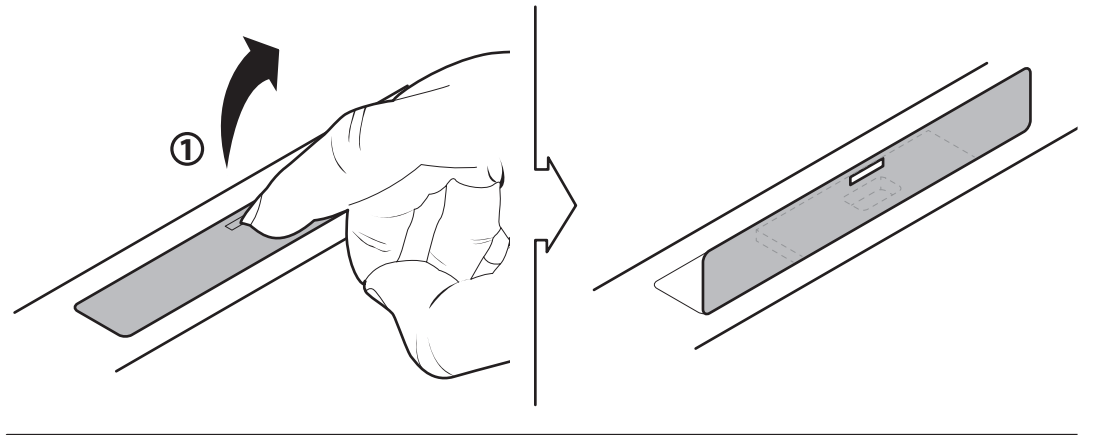

6.5

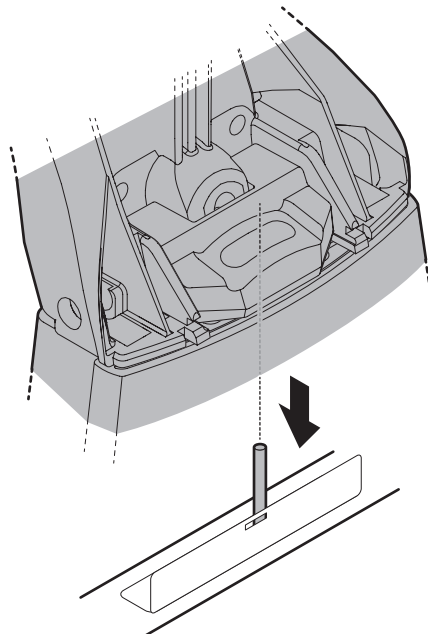
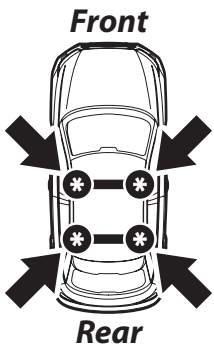



Attenzione • Warning • Attention • Hinweise • Advertencia

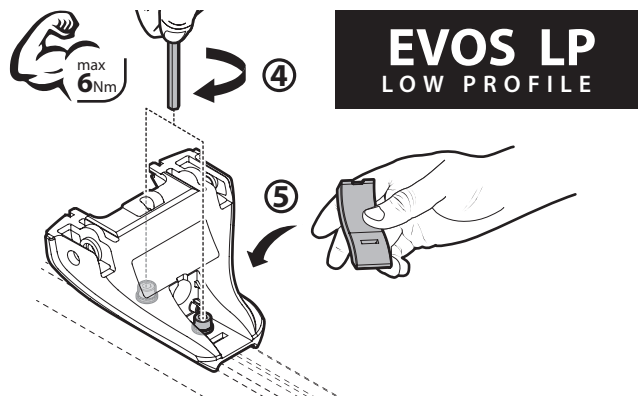
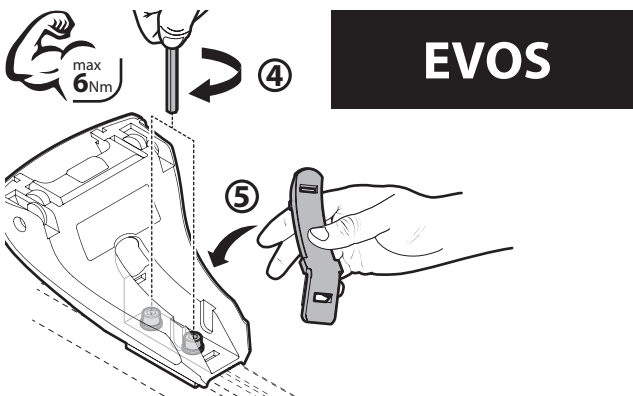
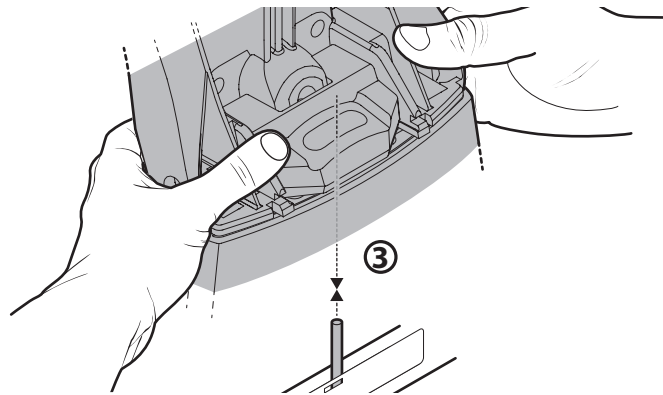
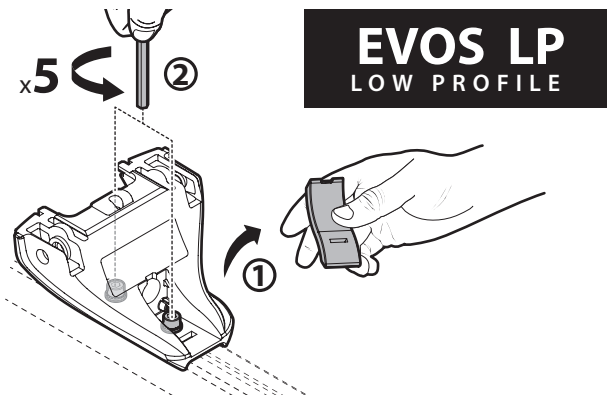
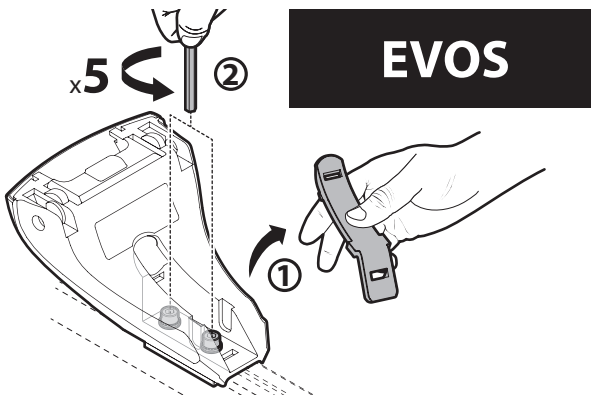
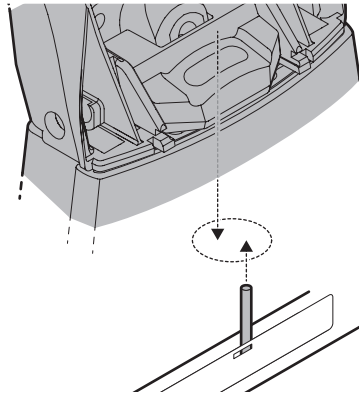
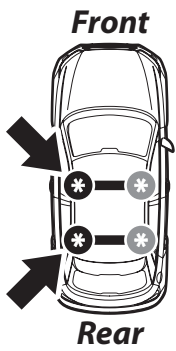

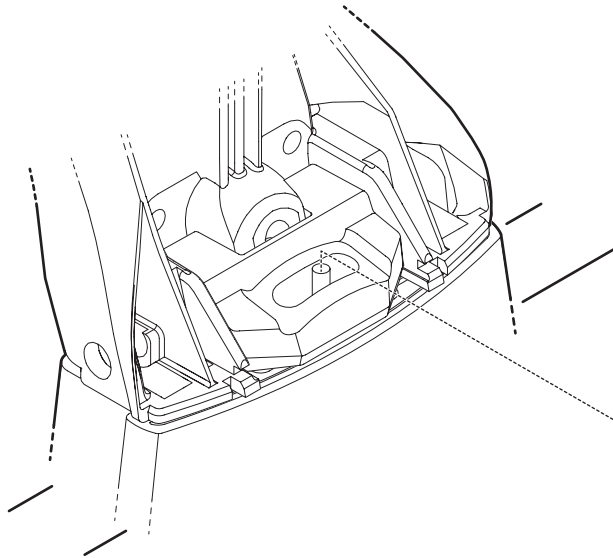
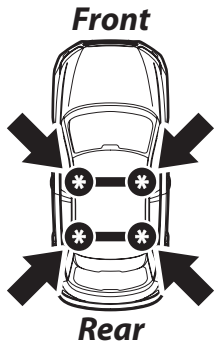

min
3Nm

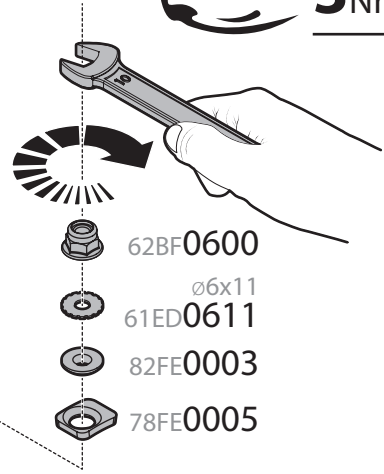

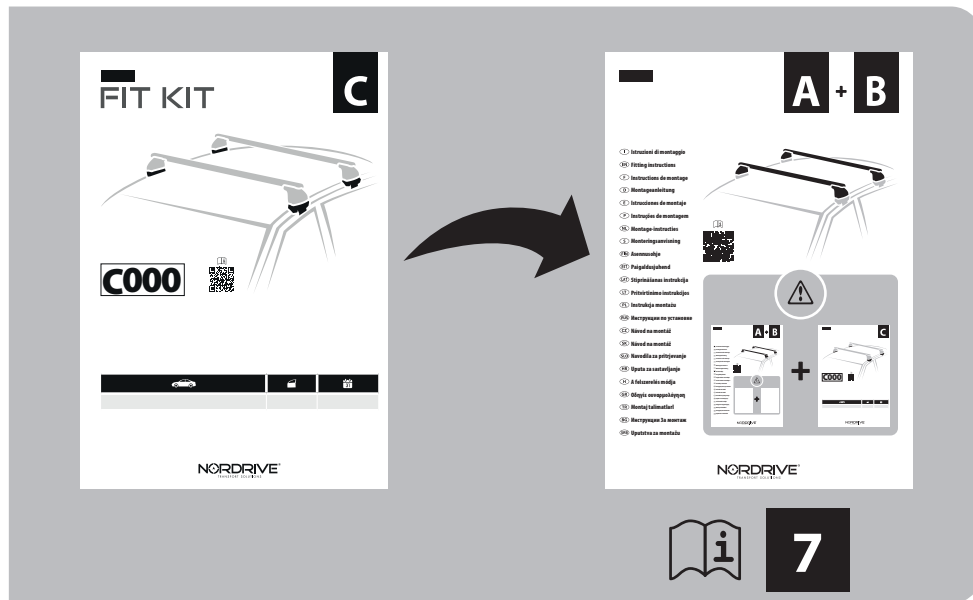

- I** Passare al manuale **A+B** e seguire le istruzioni come indicato ad intestazione pagina.
- EN** Switch to manual **A+B** and then follow the instructions as indicated above.
- F** Passez au manuel **A+B** et suivez les instructions comme indiqué ci-dessus.
- D** Das Handbuch **A+B** konsultieren und die Anleitungen wie angegeben auf Kopfzeile der Seite folgen.
- E** Vaya al manual de **A+B** y siga las instrucciones que se indican en el encabezado de la página.
- P** Passe para o manual **A+B** e siga as instruções indicadas acima.
- NL** Schakel over op manuele **A+B** en volg dan de instructies zoals hierboven aangegeven.
- S** Byt till manual **A+B** och följ där instruktionerna enligt ovan.
- FIN** Vaihda manuaaliseen **A+B** -sarjaan ja noudata sitten yllä olevia ohjeita.
- EST** Avage **A+B** juhend ja järgige ülal toodud juhiseid.
- LAT** Pārslēdzieties uz manuālo **A+B** un pēc tam izpildiet norādījumus, kā norādīts iepriekš.
- LT** Pereikite į vadovą **A+B** ir tuomet sekite instrukcijas, kaip nurodyta aukščiau.

- PL** Przełącz na ręczny **A+B**, a następnie postępuj zgodnie z instrukcjami, jak wskazano powyżej.
- RUS** Перейдите к руководству по **A+B** и следуйте инструкциям, указанным в заголовке страницы.
- CZ** Přejděte do příručky **A+B** a postupujte podle pokynů uvedených v záhlaví stránky.
- SK** Prejdite na návod **A+B** a postupujte podľa pokynov uvedených vyššie.
- SLO** Zamenjajte na navodila **A+B** in potem jim sledite kot je navedeno zgoraj.
- HR** Prebacite se na priručnik **A+B** i zatim slijedite gore navedene upute.
- H** Váltson át az **A+B** használati útmutatójára és kövesse a fenti utasításokat.
- GR** Μεταβείτε στο φυλλάδιο του **A+B** και κατόπιν ακολουθήστε τις οδηγίες που φαίνονται παραπάνω.
- TR** Manuel **A+B**'ye geçin ve ardından yukarıda belirtilen talimatları izleyin.
- BG** Преминете към ръководството **A+B** и след това следвайте инструкциите по-горе.
- SRB** Pređite na priručnik **A+B** a zatim sledite gore navedena uputstva.

- ⓘ Lotto di produzione da comunicare per eventuali ricambi
- ⓔⓃ Production lot number to be communicated for any spare parts
- ⓕ Lot de production à communiquer pour toute pièce de rechange
- ⓓ Produktionscharge für eventuelle Ersatzteile
- ⓔ Lote de producción a comunicar por cualquier repuesto

Lot.

NORDRIVE®
TRANSPORT SOLUTIONS

**NORDRIVE® is a registered trademark of
LAMPA S.p.A.**

Via G. Rossa 53/55, 46019 Viadana (MN) ITALY
Tel. +39 0375 820700

UNI EN ISO 9001:2015 Certified Company
service@lampa.it

www.nordrive.it www.lampa.it